

HPM10 Series

High Performance Laser Scanning Modules



- Unprecedented speed
- Superior accuracy and stability
- Small size for easy integration
- Bolt-on replacement for the industry-standard HPM10A
- Available with F-theta lenses for a variety of field sizes
- Compatible with standard interface cards and software
- Environmentally sealed for industrial conditions.



The HPM10VM2

The HPM10VM2 establishes the new speed and accuracy performance standards for small-aperture scan heads. With completely new and advanced scanner technology, the HPM10VM2 brings unprecedented speed to your laser system.

The HPM10M2

The HPM10M2 provides the perfect balance between performance and cost. With a completely new, simplified design, this is today's best value in scan head technology. The HPM10M2 provides speed sufficient for all but the most demanding applications as well as stability unmatched by any competitor.

Common interface

Maintaining the mechanical and electrical interface standards originally developed by GSI Group, the HPM10 series is a bolt-on upgrade for many laser systems.

Flexibility for your application

The HPM10 series scan modules are available for a wide variety of lasers, spanning UV to IR. Select from a broad range of standard flat-field lens and adapter rings to achieve the field and spot size required by your application.

Full software compatibility

Whether used with WinMCL, PCMARK MT or your own proprietary software, the HPM10 series is fully compatible and ready to integrate.

The GMAX™ advantage

GMAX stands for GSI Group Multi-Axis modules. GMAX also stands for the most advanced scanning technology available today. Put our proven expertise to work for you.

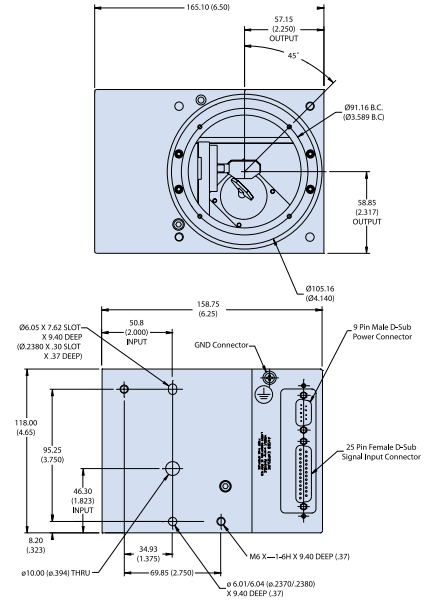

Dimensions in mm (inches). Dimensions may vary between models.

Availability with f-theta lens:

Laser Type	D-YAG		YAG			CO ₂		
Wavelength	532 nm	1,064 nm	1,064 nm	1,064 nm	1,064 nm	10,600 nm	10,600 nm	10,600 nm
Objective (f in mm)	f = 160	f = 100	f = 163	f = 254	f = 420	f = 100	f = 200	f = 300
Standard Field Size (mm)	100 x 100	55 x 55	115 x 115	180 x 180	280 x 280	60 x 60	120 x 120	180 x 180
Maximum Practical Field Size (mm)	120 x 120	70 x 70	120 x 120	180 x 180	280 x 280	60 x 60	120 x 120	180 x 180
Spot Size TEM00 (µm)	~15	~23	~31	~41	~80	~230	~380	~570
Working Distance (mm) ¹	184	108	207	338	520	76	190	285
Positioning Resolution (µm)	<4	<2	<4	<6	<9	<2	<4	<6
VM2 Writing Speed (m/s) ²	>4.5	>2.7	>4.5	>6.7	>10.5	>2.7	>4.8	>6.7
M2 Writing Speed (m/s) ²	>3.8	>2.3	>3.8	>5.6	>8.8	>2.3	>4	>5.6
Temperature Drift (typ., µm/ °C) ³	9	6	9	15	23	5	10	15
Long Term Stability (µm in 24hr.) ⁴	50	30	50	80	120	30	50	80
Power Capability, cw (W/cm ²)	500	500	500	500	500	500	500	500
Power Capability, 100 ns pulsed (MW/cm ²)	100	100	100	100	100	400	400	400
Protection Glass	Yes	Yes	Yes	Yes	Yes	Yes	Yes	Yes
Weight (kg) [Head without lens: 3.0kg]	3.8	3.8	3.8	4.3	4.3	3.3	3.3	3.3

¹ Distance between edge of head and working surface. This distance will vary with laser divergence and lens tolerance. ² Actual writing speed depends on accuracy requirements and feature sizes. Jump speeds can be significantly higher. ³ Temperature induced gain drift is 0.004 %/°C typ., 0.01 %/°C max.; offset drift is 20µR/°C typ., 30µR/°C max. Drift is specified per axis. ⁴ Long term stability after warm up is better than 300µR in 24 hrs., per axis.

Availability without f-theta lens:

	UV	Triple YAG	Visible	Argon	Argon (HP)	Double Yag	YAG	CO ₂
Wavelength	325-360 nm	355 nm	450-700 nm	480-514 nm	488-514 nm	532 nm	1064 nm	10,600 nm
Reflectivity (min.) @Wavelength (nm)	98%@325-350 95%@350-360 45%@633	99.4%@355	96.0%	98%@480-514 50%@633	99.5%	99.5%@532	99.5%@1,064 80%@450-650	99.5%
Flatness@633 nm	λ/4	λ/4	λ/4	λ/4	λ/4	λ/4	λ/4	λ/4
CW Power Capability (W/cm ²)	100	100	10	100	5MW/cm ²	500	500	500
Power Capability, 100 ns pulsed (MW/cm ²)	20 (10 ns pulsed)	20 (10 ns pulsed)	N/A	80	2GW/cm ² (10 ns pulsed)	100 (10 ns pulsed)	100	400
Surface Quality (Scratch/Dig)	40/20	40/20	40/20	40/20	40/20	40/20	40/20	40/20

Specifications are subject to change. Please consult GSI Group for complete details.

www.gsig.com/scanners



Americas
39 Manning Road
Billerica, MA 01821
U.S.A.
TEL: +1 (978) 439-5511
FAX: +1 (978) 663-0131
E-mail: ScannerSales-Americas@gsig.com
Toll Free: +1 (800) 342-3757

Europe
Einsteinstrasse 2
D-85716 Unterschleissheim
Germany
TEL: +49 (89) 31707-0
FAX: +49 (89) 31707-250
E-mail: sales.components@gsig.com

Asia
Technoport Kamata, 16-1
Minami-Kamata 2-Chome,
Ohta-Ku Tokyo 144-0035, Japan
TEL: +81 (3) 5714-0380
FAX: +81 (3) 5714-0335
E-mail: gsi_scanners@gsig.com