

# GSI Lumonics

## CX 660 Scan Control Amplifier User Manual



COMPONENTS PRODUCTS GROUP  
39 Manning Road  
Billerica, Massachusetts 01821

## Warranty Information

The Customer shall examine each shipment within 10 days of receipt and inform of any shortage or damage within that period. If no discrepancies are reported, GSIL shall assume the shipment was delivered complete and defect free. *GSIL* warrants products against defects up to 1 year from manufacture date, barring unauthorized modifications or misuse. Repaired product is warranted 90 days after the repair is made, or one year after manufacture date - whichever is longer.

Contact Customer Service to obtain a Return Materials Authorization number *before returning any product for repair*.

All orders are subject to the GSIL Terms and Conditions and Limited Warranty. Visit [www.gsilumonics.com/opticalscanning/](http://www.gsilumonics.com/opticalscanning/) for the latest version of these documents and other useful information.

**IMPORTANT:** Line Scan Engines are normally tuned, serialized and warranted as a matched set for optimized performance. Mismatched components negatively affect performance and void the warranty. A matched set typically consists of galvanometer motor, mirror load, electronic driver board and interface cable.

## Customer Support

GSI Lumonics has support services to address your questions or concerns with either the product or manual you are using. Before calling for assistance, be sure to refer to any appropriate sections in the manual that may answer your questions. Call GSI Lumonics' Customer Service Department Monday through Friday between

8 A.M. and 5 P.M. local time (GMT -05:00 Eastern Time (US & Canada)).

The customer service personnel will be able to give you direct assistance and answers to your questions.

### North America

4E Crosby Dr.  
Bedford, MA 01730  
U.S.A.  
TEL: (781) 275-1300  
FAX: (781) 275-3844  
scanning@gsilumonics.com

### Europe

Eisstenstrasse 2  
D-85716 Unterschleissheim  
Germany  
TEL: (089) 31707 0  
FAX: (089) 31707 250  
sales.components@gsilumonics.com

### Asia

Technoport Kamata, 16-1  
Minami-Kamata 2-Chome  
Ohta-Ku Tokyo 144-0035  
Japan  
TEL: (81) 3 5714 0380  
FAX: (81) 3 5714 0335  
oed-sales@gsilumonics.co.jp



Website: <http://www.gsilumonics.com/opticalscanning/>

# Table of Contents

Section	Page
<b>1. General Information</b> .....	1-1
<b>General Description</b> .....	1-1
<b>Specifications</b> .....	1-1
Input Power .....	1-1
Servo Amplifier .....	1-1
Ramp Generator .....	1-1
AGC/Voltage Regulator .....	1-1
Thermal Controller .....	1-2
Limiters and Protection .....	1-2
Physical/Environmental .....	1-2
<b>Replaceable Parts</b> .....	1-2
<b>2. Operating Procedures</b> .....	2-1
<b>Rear Panel Controls and Connectors</b> .....	2-1
Line Voltage Selector Switch .....	2-1
AC Power Cord Receptacle and Fuse Holder .....	2-2
Output Connector .....	2-2
Servo Amplifier Calibration .....	2-2
<b>Front Panel Controls and Connectors</b> .....	2-3
Signal Controls .....	2-3
Scanner Outputs .....	2-4
Ramp Generator .....	2-4
Power Switch .....	2-4
<b>Initial Operation and Calibration</b> .....	2-5
<b>3. Calibration/Adjustment Procedure</b> .....	3-1
<b>Position Gain and Offset Calibration</b> .....	3-1
<b>Servo Amplifier Adjustments</b> .....	3-3
<b>4. Circuit Description</b> .....	4-1
<b>Introduction</b> .....	4-1
<b>Power Supply</b> .....	4-1
<b>Servo Amplifier</b> .....	4-1
<b>AGC/Voltage Regulator</b> .....	4-2
<b>Temperature Regulator</b> .....	4-3
<b>Ramp Generator</b> .....	4-3
<b>5. Trouble Shooting</b> .....	5-1
<b>6. Diagrams</b> .....	6-1

# List of Illustrations

Figure		Page
2-1	Rear Panel .....	2-1
2-2	Voltage Selector Switch .....	2-1
2-3	AC Power Cord Receptacle and Fuse Holder .....	2-2
2-4	Output Connector .....	2-2
2-5	Front Panel .....	2-3
2-6	Signal Controls .....	2-3
2-7	Scanner Output Signals .....	2-4
2-8	Ramp Generator .....	2-4
2-9	Scanner Rotation .....	2-5
3-1	Optical Test Bench .....	3-1
3-2	Cover Removal .....	3-2
3-3	Printed Circuit Card .....	3-3
3-4	Over-Damped Response .....	3-4
3-5	Critically Damped Response .....	3-4
3-6	Under-Damped Response .....	3-4
4-1	Top View of Unit Without Cover .....	4-1
6-1	Interconnection Diagram CX660 3ID-06857 .....	6-2
6-2	Assembly Diagram P.C. 311-06855 .....	6-3
6-3	Schematic Diagram 3SD-06856 .....	6-4

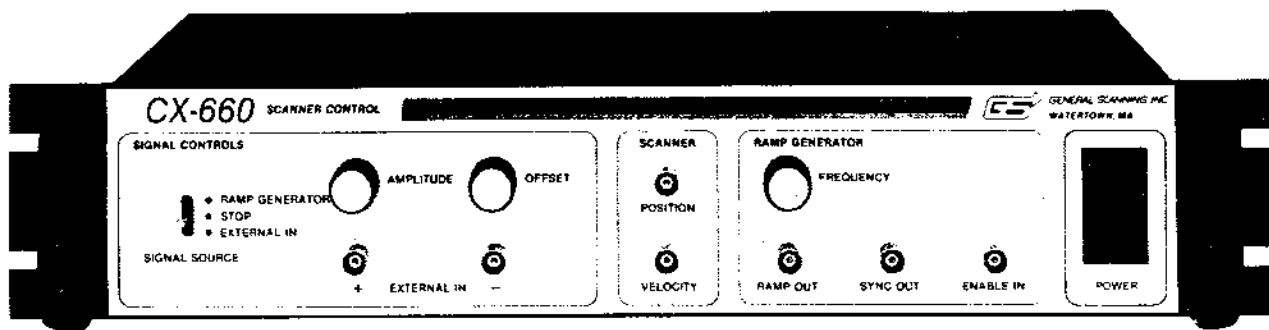

**CX660 Control Amplifier**

# Section 1

## General Information

### General Description

The CX660 scanner control contains all the circuitry required for operating General Scanning's closed loop galvanometric scanners. It includes: a regulated  $\pm 15V$  power supply, a multiloop amplifier, a closed loop temperature regulator, an automatic gain control/voltage regulator, and a ramp generator.

The CX660 circuitry is designed for the optimal control and response of a GSI galvanometric scanner while maintaining low noise and good position stability. Both the scanner and controller are protected by the circuitry from most fault conditions.

Special attention has been given to the instrument's grounding. The chassis is connected to the "earth" or "safety" ground. Signal ground and chassis ground are intentionally separated. This ground separation, combined with the external differential inputs, simplifies systems integration.

### Specifications

#### Input Power

105-125/210-250 VAC  
50/60 Hz  
Approximately 60 Watts

#### Servo Amplifier

Specification Temperature:  
 $20^{\circ}C \pm 10^{\circ}C$

Warm-up Time:  
Less than 15 minutes

Input Voltage Range:  
External In +      $-10V$  to  $+10V$   
External In -      $-10V$  to  $+10V$

Input Impedance:

External In +      $10\text{ k} \pm 1\%$   
External In -      $5\text{ k} \pm 1\%$

CMRR

60 dB minimum,  $R_s \leq 50$  ohms

Position Signal:

10V, p-p @ full rated angle

Centering Range:

$\pm 50\%$  of full angle minimum

Gain Drift:

0.01%/ $^{\circ}C$  maximum

Offset Drift:

10 arc seconds/ $^{\circ}C$  maximum

Position noise:

50  $\mu V$  p-p, maximum 1 Hz to 10 kHz

#### Ramp Generator

Frequency Range:

1 Hz to 150 Hz minimum

Ramp Non Linearity:

1% maximum

Ramp Amplitude:

$-5$  to  $+5V \pm 10\%$

Wave Form:

2 retrace slopes possible

Sync Out:

TTL compatible

Enable In:

TTL compatible

#### AGC/Voltage Regulator

Output Voltage:

$+12V \pm 5\%$  as voltage regulator  
Nominal  $+12$  Volts in AGC mode

## Thermal Controller

Set Point:

40°C ± 4°C

Set Point Stability:

± ½°C maximum, fixed ambient

Thermal Regulation:

0.1°C/°C ambient

Load Regulation:

0.2°C/Watt into scanner

## Limiters and Protection

\* Over Temperature Shutdown:

\*\* @ 70°C ± 7°C ( $R_T \leq 105$  ohms)

\* Open Thermistor Shutdown:

\*\*  $R_T \geq 5$  k

± 15 Volt power supplies are current limited and short-circuit protected.

Transconductance output stage is short-circuit protected.

Scanner DC current is limited to safe limit.

\* Scanner excursion is limited by over-position shutdown.

Servo gain is limited during instrument power-up and power-down.

Temperature regulator is short-circuit protected.

AGC (voltage regulator) is short-circuit protected.

All inputs are clamped to internal supply voltages.

\* Can be internally defeated.

\*\*  $R_T$  is resistance of scanner's thermistor.

## Physical/Environmental

Storage Temperature:

-20°C to +80°C

Ambient Operating Temperature:

0°C to 40°C

Weight:

7.5 lbs (3.4 kg)

Size:

19" W (rack mount) × 3.45" H × 7.25" D  
(48.3 cm W × 8.76 cm H × 18.41 cm D)

## Replaceable Parts

	GSI	OTHER SOURCE
230 V fuse	164-1707	Little Fuse #213.500
115 V fuse	164-1706	Little Fuse #213.001
Line cord	167-7351	Switchcraft #P-2727
Scanner extension cable (6 feet long)	312-07394-1	

# Section 2

## Operating Procedures

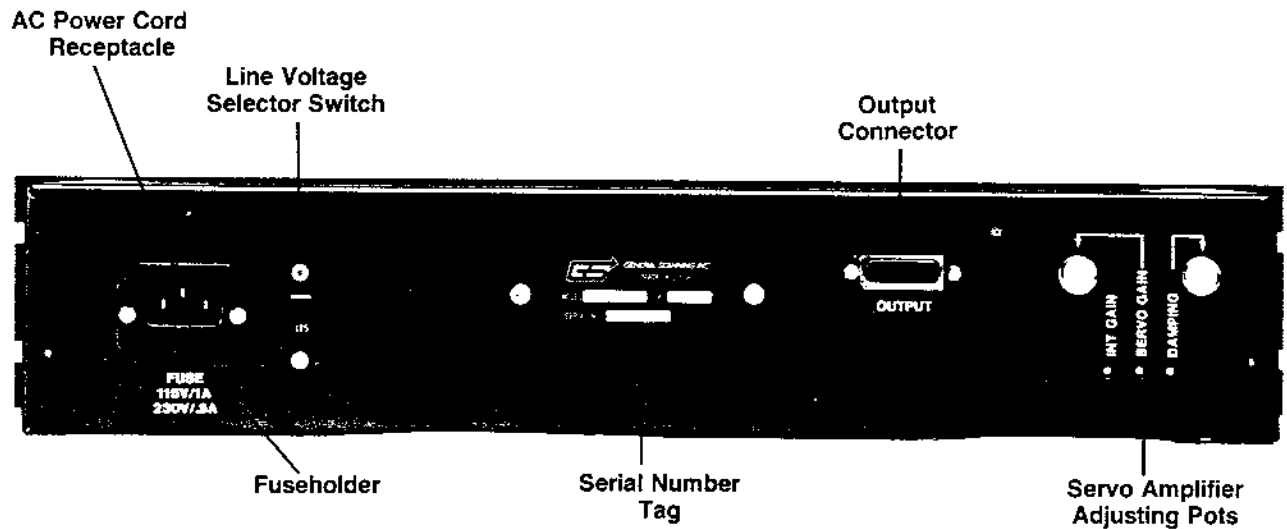

Figure 2-1 Rear Panel

### Rear Panel Controls and Connectors

**CAUTION**

Before connecting the line cord to the CX660 or the AC mains, make certain the line voltage selector is set to **your** line voltage and that the corresponding fuse is installed.

### Line Voltage Selector Switch

The CX660 may be operated from 115 or 230 VAC 50/60 Hz power. Set the Line Voltage Selector to *your* line voltage.

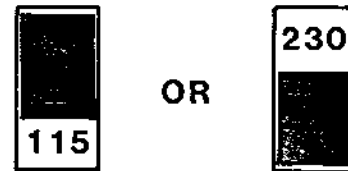
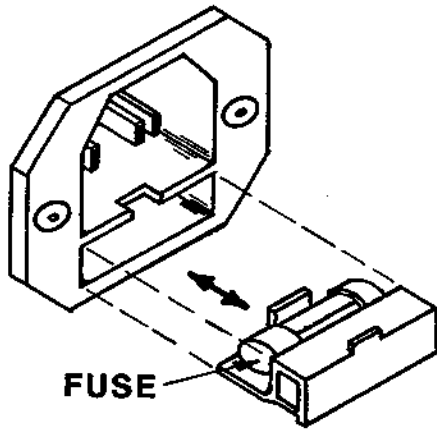

Figure 2-2 Voltage Selector Switch



**Figure 2-3** AC Power Cord Receptacle and Fuse Holder

### AC Power Cord Receptacle and Fuse Holder

Make certain the proper fuse is inserted into the fuse holder. To inspect the fuse, the power cord must be detached from the amplifier. A small screwdriver is used to pry open the fuse holder (See Figure 2-3).

For 115 VAC, use a 1 A slow-blow fuse;  
For 230 VAC, use a 1/2 A slow-blow fuse.

#### CAUTION

**Never** install a fuse of improper size or type in the CX660.

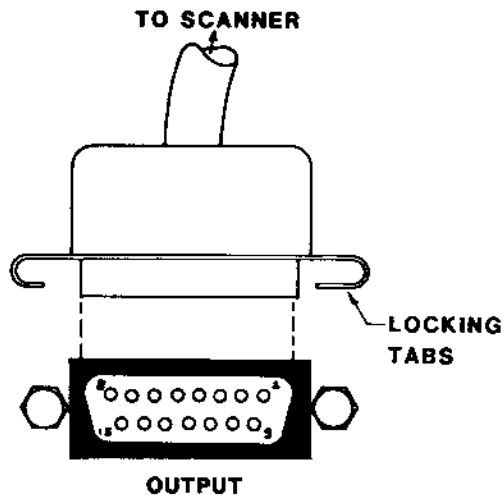

**Figure 2-4** Output Connector

### Output Connector

Plug the scanner's 15 pin "D" connector into the CX660 OUTPUT connector. The connector's metal housing slides under the locking tabs on the control amplifier, locking the connector in place. All signals between the scanner and the control are conducted through this connector.

### Servo Amplifier Calibration

The servo amplifier calibration potentiometers are accessible through an opening on the rear panel. When a scanner and a CX660 are purchased together, the servo amplifier is adjusted at General Scanning, using the standard mirror inertia\* for that particular scanner. These potentiometer settings should only be changed according to the instructions in Section 3 (Servo Amplifier Adjustments).

\* See Appendix B for standard mirror inertias.

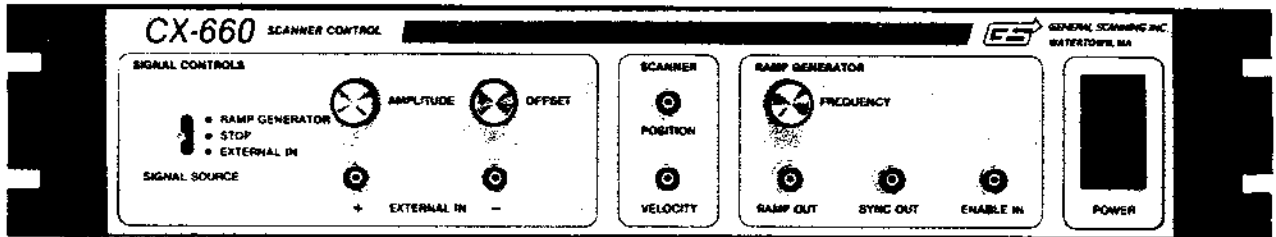

Figure 2-5 Front Panel

## Front Panel Controls and Connectors

The front panel is divided into four sections: SIGNAL CONTROLS, SCANNER, RAMP GENERATOR, and POWER.

### Signal Controls

The SIGNAL CONTROLS section selects and conditions the input signals (See Figure 2-6).

The SIGNAL SOURCE switch selects the origin of the input signal. When set to RAMP GENERATOR, the servo amplifier input is *internally* connected to the RAMP OUT signal. When set to STOP, the servo amplifier input is connected to ground. When set to EXTERNAL IN it is connected to the output of a differential amplifier which receives its input signals through the BNC connectors labeled EXTERNAL IN + and -.

The BNC connectors, + EXTERNAL -, are inputs to a unity gain differential amplifier. When the EXTERNAL IN signal source has been selected, the equivalent voltage difference between "+" and "-" of EXTERNAL IN is connected to the amplitude control potentiometer.

**NOTE:** EXTERNAL IN - may be used as a single-ended inverting input.

EXTERNAL IN + may be used as a single-ended input, but EXTERNAL IN - must be connected to ground for proper signal amplitude.

The AMPLITUDE control, a ten-turn linear potentiometer, adjusts the input signal supplied to the servo amplifier. Turning the control clockwise increases the signal level.

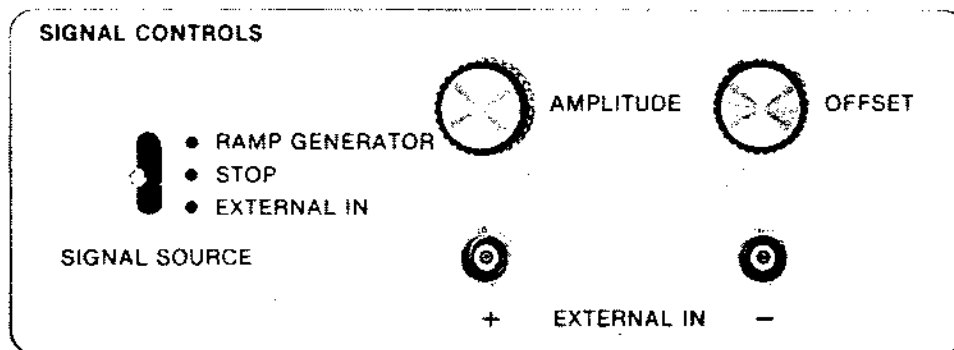

Figure 2-6 Signal Controls

The OFFSET control, also a ten-turn linear potentiometer, inputs either a positive or negative DC voltage to the servo amplifier. The signal from the OFFSET control is independent of the AMPLITUDE control setting. (A clockwise rotation of the OFFSET knob causes the scanner to move counter clockwise and the scanner POSITION signal to become more negative.)

### Scanner Outputs

The two BNC connectors in the SCANNER section output signals processed from the scanner's position detector (See Figure 2-7).

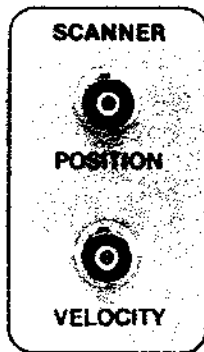

Figure 2-7 Scanner Output Signals

The POSITION signal is the analogue of the scanner's actual rotor position. No externally accessible controls change the calibration of the POSITION signal.

The VELOCITY signal is the analogue of the scanner's actual rotor velocity. Adjustments to DAMPING affect the calibration of the VELOCITY signal.

### Ramp Generator

Controls and connectors in the RAMP GENERATOR section affect the RAMP GENERATOR signal only (See Figure 2-8).

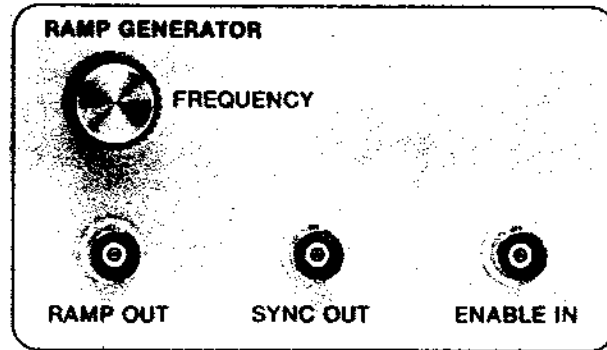

Figure 2-8 Ramp Generator

The FREQUENCY control, a ten-turn linear pot, changes the free-running frequency of the RAMP GENERATOR signal. This potentiometer adjusts the slope of the ramp while having little effect on the retrace time.

RAMP OUT is wired through a resistor to the same signal that is applied to the servo amplifier input when the SIGNAL SOURCE switch is set to RAMP GENERATOR.

SYNC OUT is a TTL compatible signal whose state is low during the retrace interval.

ENABLE IN accepts a TTL compatible signal and initiates a ramp when allowed to go high for more than a few microseconds. If ENABLE IN transitions to the low state during a ramp, the ramp will continue until the next retrace interval.

A free-running, fast retrace mode is obtained when ENABLE IN is externally connected to SYNC OUT.

A synchronized ramp with fast retrace is obtained with short ENABLE pulses.

### Power Switch

The POWER switch turns the unit and its power indicating light on and off.

**CAUTION**

**Be sure the line voltage selector is set to your line voltage before connecting this instrument to the AC mains.**

## Initial Operation and Calibration

*The CX660 must be adjusted for each scanner.*

**NOTE:** If the CX660 and the scanner were purchased together, the factory will have adjusted the control amplifier for the scanner. Unless inertial loads applied to the scanner have been changed, no further adjustments should be required.

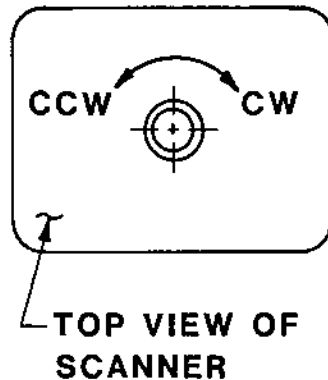

**Figure 2-9** Scanner Rotation

Every scanner has a unique position transducer sensitivity. The position signal amplifier in the CX660 must be calibrated to the position transducer of the scanner it drives. A correctly calibrated CX660 outputs a +5 volt position signal when the scanner is at its specified maximum angle of clockwise rotation and -5 volts when at the specified maximum angle of counter clockwise rotation. The position signal should be equal to zero volts when the scanner is at the midpoint of these two extremes.

The dynamic performance of the scanner when driven by the CX660's servo amplifier also needs to be checked. If the CX660 and the scanner were *not* purchased at the same time, see Section 3, CALIBRATION/ADJUSTMENT PROCEDURE for appropriate steps.

# Section 3

## Calibration/Adjustment Procedure

Equipment required:

- 0.5 milliwatt He-Ne laser
- Optical bench
- Calibrated angular scale
- Function generator
- Oscilloscope

### CAUTION

Before connecting the scanner to the scanner control, check to verify compatibility (see Appendix A).

With the scanner connected to the CX660 and the POWER switch off, mount the scanner to the optical bench. Turn the scanner body so that the laser beam is reflected to the zero point of the angular scale.

### CAUTION

Excessive excursion angles and/or extreme oscillations can severely damage your scanner.

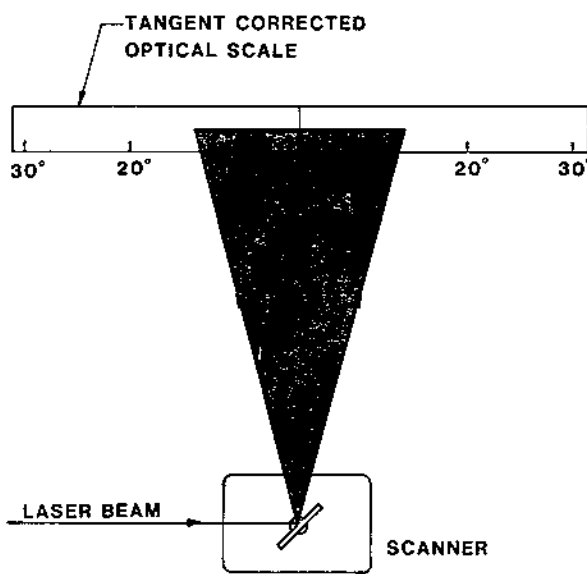

Figure 3-1 Optical Test Bench

Set the scanner control SIGNAL SOURCE switch to STOP and turn on POWER. Connect the oscilloscope to the SCANNER POSITION connector. If the scanner beam has moved from the center ( $0^\circ$ ) of the position scale, adjust the OFFSET control so the beam again points at zero. The position voltage should be less than  $\pm 250$  mV. If not, the CX660 needs an internal offset adjustment (See next section).

Set the function generator to output a  $\pm 10$  volt peak 20 Hz square wave. Turn the AMPLITUDE control fully counter clockwise and connect the square wave signal to the EXTERNAL IN - connector. Select EXTERNAL IN with the SIGNAL SOURCE switch. Slowly turn the AMPLITUDE control clockwise. The reflected beam should start to swing back and forth between two points. Adjust the AMPLITUDE control for a 10 optical degree positive and negative excursion of the reflected laser. The POSITION signal should be a good approximation to a square wave. A more stable oscilloscope trace is usually obtained when the function generator signal is connected to the oscilloscope's external trigger input. If the POSITION signal square wave shows ringing or considerable distortion, the servo amplifier parameters must be adjusted. If the POSITION signal amplitude is not  $\pm 2.5$  volts when the scanner is rotating through  $\frac{1}{2}$  of its maximum rated angle, the position demodulator gain must be adjusted (See next section).

### Position Gain and Offset Calibration

The scanner, in combination with the position signal amplifier circuit, generates the position signal. This position signal is used as an input to the servo amplifier and as an input to the limiting circuits. It is important that when the scanner reaches its maximum rated angles of rotation, the absolute value of the position

signal be equal to 5 volts. To calibrate the position demodulator, the top cover of the CX660 must be removed.

**WARNING**

**Hazardous voltages are exposed when the top cover of this instrument is removed. This procedure should be performed by qualified personnel only.**

To remove the top cover, disconnect the power cord and turn the unit over. Remove the four screws from the corners of the bottom panel. Remove the five screws around the perimeter of the rear panel. Return the unit to an upright position. The whole cover should now be free to slide towards the rear of the unit.

Set the CX660 controls to the following conditions (See Figure 3-3):

**Front Panel:**

POWER switch to off  
SIGNAL SOURCE to STOP  
AMPLITUDE fully counter clockwise

**Rear Panel:**

SERVO GAIN fully counter clockwise  
DAMPING approximately mid range  
INT GAIN fully clockwise

**Internal Switches and Controls:**

S101 Section 1 closed  
S101 Section 2-4 closed  
S102 Section 1-4 open  
S103 Section 1 and 2 closed  
S103 Section 3 is open  
S103 Section 4 closed  
R111 fully counter clockwise  
R120 fully clockwise

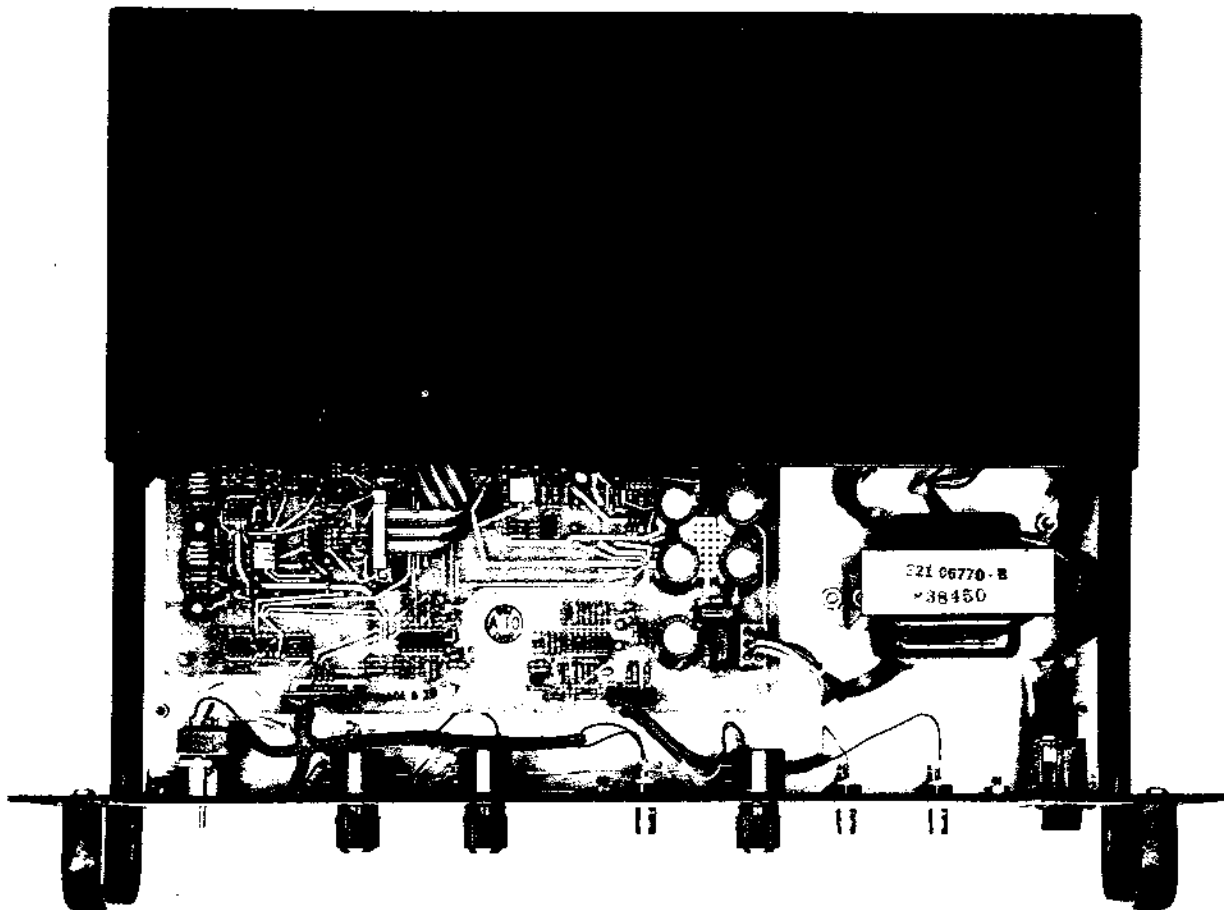

Figure 3-2 Cover Removal

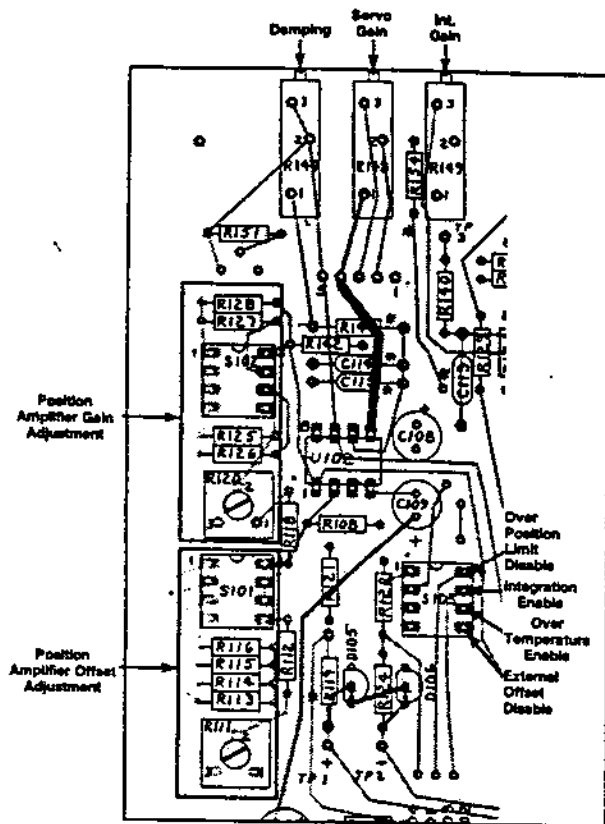

Figure 3-3 Printed Circuit Card

**CAUTION**

Excessive excursion angles and/or extreme oscillation can damage your scanner.

Be sure the scanner is pointing to the zero position with the POWER switch off.

Turn the POWER switch to on and, using the front panel OFFSET control, set the POSITION signal to zero. The directed laser spot will probably not point to zero since the CX660 is not fully adjusted. S101 Section 1 is closed. If the scanner spot is to the left of zero, Section 1 should be opened.

Open S101 Section 2, the laser spot will jump to the left. If the laser spot remains to the right of the zero, S101 Section 2 should remain open. However, if the spot goes to the left of zero, the chosen switch section has over compensated and should be opened again. Repeat this procedure for Sections 3 and 4 of S101.

When the switch combination which brings the directed spot closest to zero *without going left of zero* has been found, turn R111 clockwise until the spot rests exactly on zero. This procedure completes the position demodulator *offset* calibration.

The position gain calibration is conducted in a similar manner. Using the OFFSET control on the front panel, adjust the POSITION signal to 2.50 volts. Again, the laser spot moves to the right of zero, but at an angle less than 1/2 rated angle. By closing S102 Section 1 thru 4, the laser spot will move further right. In the same manner as above, select the switch combination which causes the laser spot to move as close to 1/2 rated angle as possible without going beyond. Finally, turn R120 counter clockwise until the laser spot is resting on 1/2 rated angle on the optical scale.

Open switch S103 Section 1. This reinstates the over-position shutdown.

This short procedure completes the position demodulator calibration. *The servo amplifier parameters must also be adjusted. See the following section.*

## Servo Amplifier Adjustments

**NOTE:** This procedure requires that the position amplifier be calibrated (See Position Gain and Offset Calibration).

Set the CX660 controls as follows:

Front Panel:

- SIGNAL SOURCE switch to EXTERNAL IN
- AMPLITUDE control two turns from fully counter clockwise
- EXTERNAL IN — connected to a  $\pm 10$  V 20 Hz square wave.

Back Panel:

- SERVO GAIN fully counter clockwise
- DAMPING approximately mid range
- INT GAIN fully counter clockwise

Internal Switches:

- S103-1 open and S103-3 open
- S103-2 closed

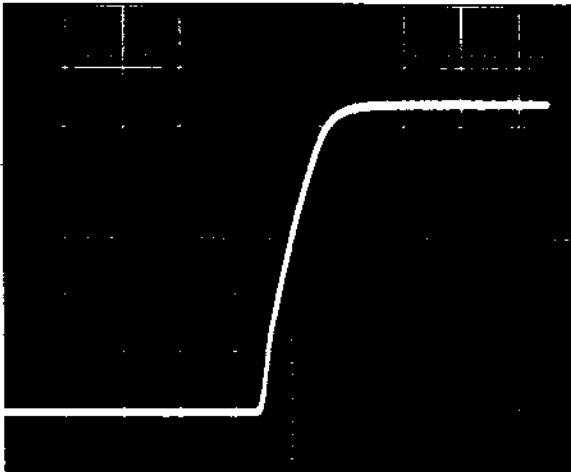

Figure 3-4 Over-Damped Response

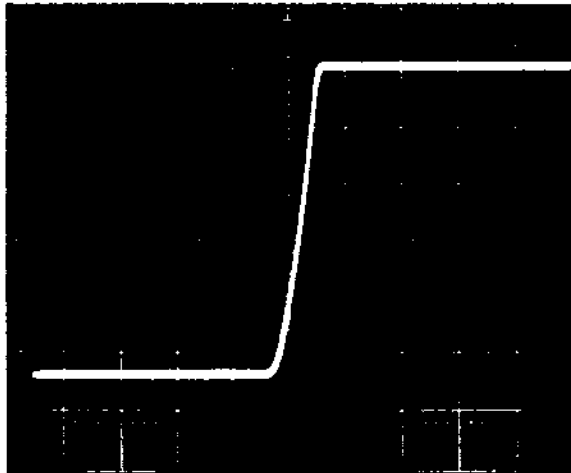

Figure 3-5 Critically Damped Response

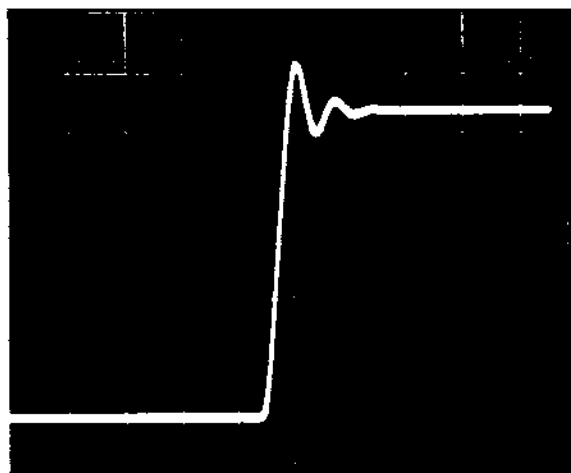

Figure 3-6 Under-Damped Response

Slowly turn the SERVO GAIN pot clockwise until the scanner starts to move. Adjust the front panel OFFSET control so that the laser spot is approximately centered. While monitoring the POSITION signal, adjust the SERVO GAIN and the DAMPING to obtain a reasonable approximation to a square wave. An over-damped response is best at this time.

Adjust the AMPLITUDE control so that the scanner is rotating through its full angle of excursion. The position signal should be alternating back and forth synchronously with the scanner at an amplitude of  $\pm 5$  volts. *If the position signal is not 5 volts when the scanner is at its maximum rated angle, return to the previous section and recalibrate the position demodulator.*

At this point, the servo gain and damping should be adjusted to obtain critical damping and to minimize the full angle rise time. The fastest rise time is obtained by using the maximum servo gain allowed by the available damping. As the servo gain is increased, the amplitude control will need to be decreased to keep the scanner rotating at its maximum rated angle. If the rated angle of the scanner is exceeded during the adjustment, the over-position protection circuit will be triggered and shut down the amplifier momentarily.

At some point during the servo gain adjustment procedure, further increases in servo gain will degrade the scanner response. Reducing the servo gain slightly may actually improve the settling time. Patience is required to get a feel for each control and to optimize the adjustment of the amplifier. After the amplifier has been adjusted to obtain critical damping without the integrator (i.e. INT GAIN fully counter clockwise) it can be adjusted as an integrating servo amplifier.

Reduce the scanner amplitude slightly, and slowly turn the INT GAIN clockwise. The scanner amplitude will increase again as the integrator starts to function. Adjust the INT GAIN pot to obtain a squared-up leading edge to the position signal, while the scanner is swinging through its full scale excursion.

If your scanner has the temperature control option (i.e. a "T" in its part number), close S103 Section 3. This will activate the over-temperature shutdown circuitry. If your scanner is *not* temperature controlled, do not close this switch as this will **disable** the servo amplifier.

**NOTE<sup>1</sup>:** If for any reason the CX660 is severely uncalibrated as a result of changing the inertial load on the scanner, driving a different scanner, etc., the servo loop may become unstable. The instability will show up as self-oscillation of the scanner. To prevent this, turn the SERVO GAIN

and INT GAIN fully counter clockwise and turn the DAMPING control to mid range. If the scanner oscillates after these adjustments, it will be necessary to change amplifier components. Please consult the factory for changes.

**NOTE<sup>2</sup>:** If the thermistor in a thermally controlled scanner is shorted or open, or if a scanner without thermal control (open thermistor) is connected to the CX660, and S103-3 is closed, the servo amplifier will be shut down. S103-3 enables the over-temperature shutdown.

# Section 4

## CX660 Circuit Description

### Introduction

The CX660 has five major circuit blocks: The power supply, the servo amplifier, temperature regulator, AGC/voltage regulator, and the ramp generator. All of these circuits are shown in Figure 6-3, the A660 Schematic 3SD-06856.

### Power Supply

The A660 power supply is a standard contemporary linear power supply. The two industry-standard adjustable voltage regulators, U201 and U202, are connected so as to minimize noise and ripple. These regulators have built-in current limit, thermal overload protection, and safe operating area protection, eliminating the need for fuses in the  $\pm 15$  volt supplies. The  $\pm 15$  volt supplies can be disconnected from the other circuits by removing jumper wires W201 and W202. The  $-15$  volt supply can be adjusted to match the  $+15$  volt supply with R205.

A second unregulated power supply,  $+30$  volts, is used as the heater blanket supply for thermally controlled scanners.

The power transformer has a split primary allowing the amplifier to be used with either 115 or 230 volt 50/60 Hz power lines. A fuse in the primary circuit is located in the line cord connector. The secondary of the power transformer is connected to the A660 printed circuit card via J3, a six-pin Molex connector.

### Servo Amplifier

The A660 servo amplifier compares the signal generated by the position transducer to an input signal, then causes a current proportional to this difference in the scanner drive coils. The direction of the current causes the scanner to rotate so as to minimize the position error signal T.P.3. When the amplifier is set up as an

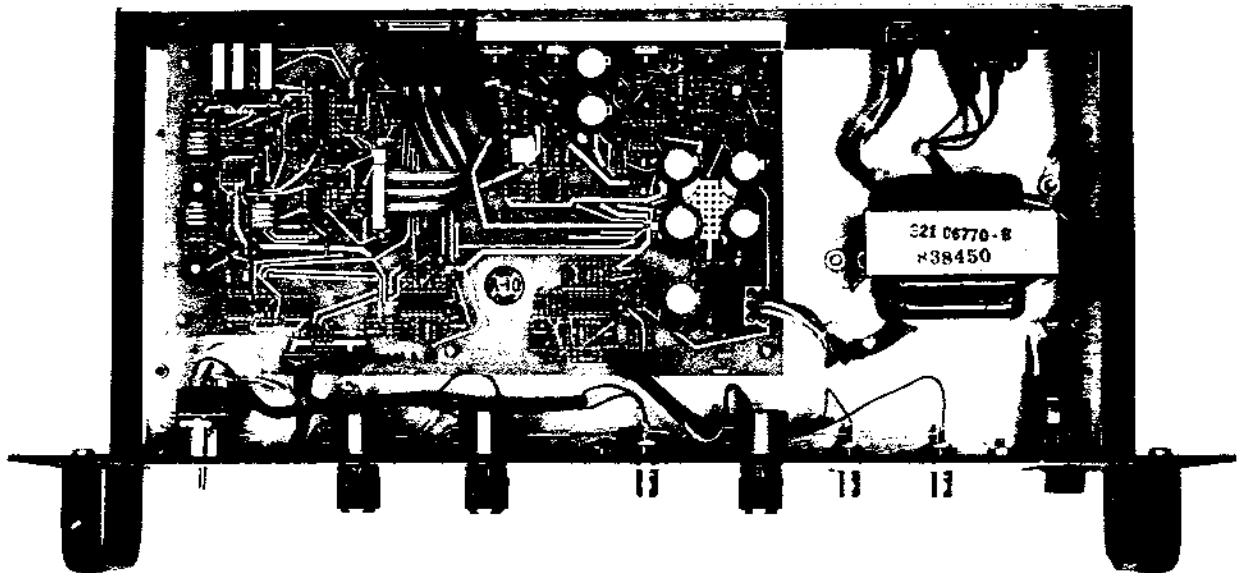

Figure 4-1 Top View of Unit Without Cover

integrating servo, the position signal will be equal to the input voltage, i.e. for a DC input voltage the integrating servo reduces the position error voltage to zero.

Input voltages are applied to the A660 by way of a unity gain differential preamplifier, U103 and its associated circuitry. The preamplifier allows input signals of either polarity to drive the scanner clockwise. A thin film resistor network with a 0.1% resistor matching assures gain stability, insensitivity to temperature changes, and a high common mode rejection ratio.

The scanner position transducer produces a differential output current proportional to rotor position. This current is converted to a position voltage by the current-to-voltage converter, U101. The position voltage is calibrated, i.e. offset errors subtracted and position transducer gain adjusted by U102, S101, S102, R111, R120.

The calibrated position signal is connected to the position error amplifier, part of U105, and is then subtracted from the output of the preamplifier to generate the position error signal, T.P.3. The position error voltage is applied to the transconductance output stage to produce current in the drive coils of the scanner.

The servo gain potentiometer, R148, adjusts the fraction of position error voltage fed to a summing amplifier, part of U105. The second input to this stage is from the differentiator. The differentiator, part of U102, generates a voltage proportional to the rate of change of the position signal, i.e. differentiates the position signal. When all adjustments are correct, the summing amplifier's output voltage becomes the current which optimally controls the scanner. This voltage can be observed at T.P.4.

The position error signal, T.P.3, is also connected to the integrator, part of U105. If S103 Section 2 is closed and, if the integrator is properly adjusted, the integrator can drive the position error signal to zero. However, the position error signal will not go to zero if the input signal is changing, as the integrator cannot instantaneously follow changes in the position error voltage.

The voltage across R184, T.P.5, is proportional to the current in the scanner drive coils. This voltage is used as an input to the current limiter circuit, part of U104. The current limiter circuit keeps the output stage from overheating the scanner in fault conditions.

The output stage is a push-pull emitter follower with Darlington transistors as output drivers, Q107 and Q108. While the design protects against short circuits, peak currents required by the scanner in transient conditions are supplied. R173 is used to adjust the quiescent current through the output transistors. This factory-set current minimizes crossover distortion which can cause the output to oscillate around zero.

The scanner position signal is also connected to the over-position shutdown circuit. When the scanner position signal exceeds  $\pm 5$  volts, this circuit (Q101, Q102) drastically reduces the servo gain and resets the integrator to zero. When the scanner position detector is properly calibrated, the over-position shutdown circuit protects the scanner from damage due to over-angle position requests. The over-position shutdown feature can be by-passed by closing S103 Section 1.

High D.C. stability is achieved by using two precision voltage references, D105 and D106. These references, with a maximum temperature co-efficient of 50 parts-per-million/ $^{\circ}$ C, insure a stable voltage for offset correction and the position oscillator reference voltage.

## **AGC/Voltage Regulator**

An integral part of position stability is the stabilization of the scanner position oscillator, which is located in the scanner. The AGC/voltage regulator circuit is used to generate the supply voltage for the scanner position oscillator. When this circuit is in the AGC mode, R501 supplies the current to charge an NPO capacitor located on the position oscillator board. The NPO capacitor is discharged by the position oscillator voltage; the same voltage that energizes the position detector.

Any change in the oscillator frequency or amplitude changes the NPO capacitor discharge rate. The AGC circuit forces the rate of discharge of the NPO capacitor to remain constant by controlling the oscillator supply voltage.

When the AGC/voltage regulator is used as a low noise voltage regulator, R510 must be connected. The voltage regulator mode is not compatible with scanners that are connected for AGC. J5 pin 8 (pin #12 on the scanner connector) should not be connected to the scanner. The regulated output voltage is 12 volts  $\pm 5\%$ .

## Temperature Regulator

The temperature regulator circuit is for use with thermally controlled scanners. These scanners have a thermistor inside the scanner and a heater blanket on the outside. The thermistor forms one leg of a bridge circuit. The output of the bridge is connected to a high gain amplifier whose output drives the scanner's heater blanket. Temperature controlled scanners are elevated to a nominal temperature of 40°C. The set point can vary as much as  $\pm 4^\circ\text{C}$  because of thermistor tolerance, but the set point will remain stable to within  $\frac{1}{2}^\circ\text{C}$  once the scanner reaches temperature. Com-

ponents of the temperature regulator have been chosen so that the controller is critically damped.

As part of the thermal control circuit, an over-temperature shutdown circuit is implemented. If the thermistor inside the scanner is shorted or open or the scanner exceeds 70°, the gain of the servo amplifier is drastically reduced.

S103 Section 3, when closed, enables the over-temperature shutdown circuit. S103 Section 3 must be open if the temperature control circuit is not used.

## Ramp Generator

The ramp generator is a self-contained saw-tooth oscillator which oscillates at frequencies between 1 Hz and 150 Hz. The two slopes generated when in the free-run mode are the result of integrating a D.C. voltage via two different paths. C404 is the integrating capacitor. The voltage sent to the integrator is controlled by the frequency adjustment potentiometer on the front panel. ENABLE IN and SYNC OUT are TTL compatible control signals. When ENABLE IN is connected to ground, the ramp already in progress will be completed, but subsequent ramps will be disabled. When ENABLE IN is connected to SYNC OUT, a fast retrace, free-running oscillator is obtained.

# Section 5

## Trouble Shooting

### **No Indicator Light**

- Check power cord connection, both ends.
- Check fuse, located in power cord connector.

### **Scanner Does Not Respond to Input Signal**

- Check Compatibility Chart, Appendix A.
- Select RAMP GENERATOR.
- Check Scanner "D" connector.
- Check  $\pm 15$  volts output at "D" connector (See Interconnection Diagram).

### **Scanner Oscillates with No Signal Applied**

- Read Section 3, Servo Amplifier Calibration.

Check the inertial load (See Table of Inertial Loads, Appendix B).

Should you continue to have difficulty with your unit, contact Sales Engineering, General Scanning, Inc. for assistance.

# **Section 6 Diagrams**



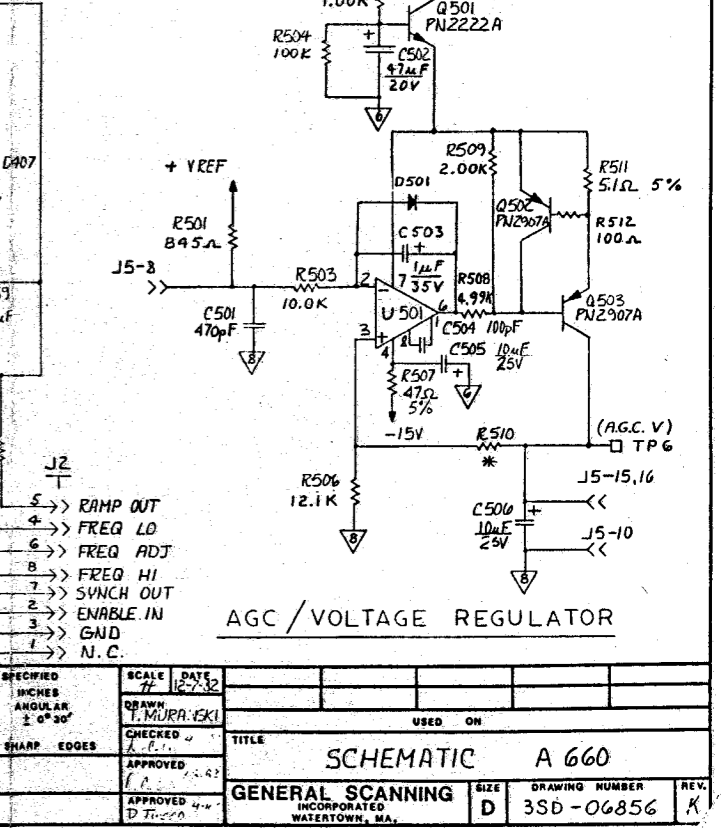
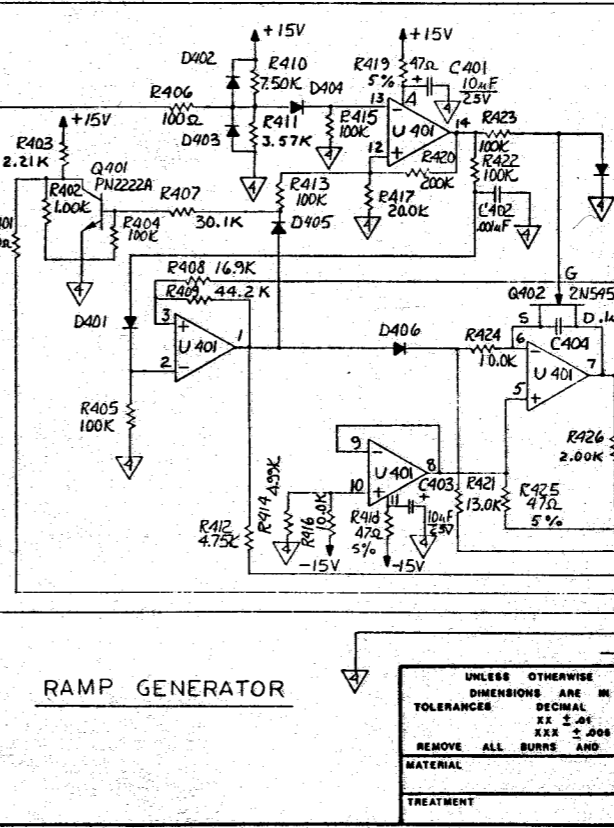
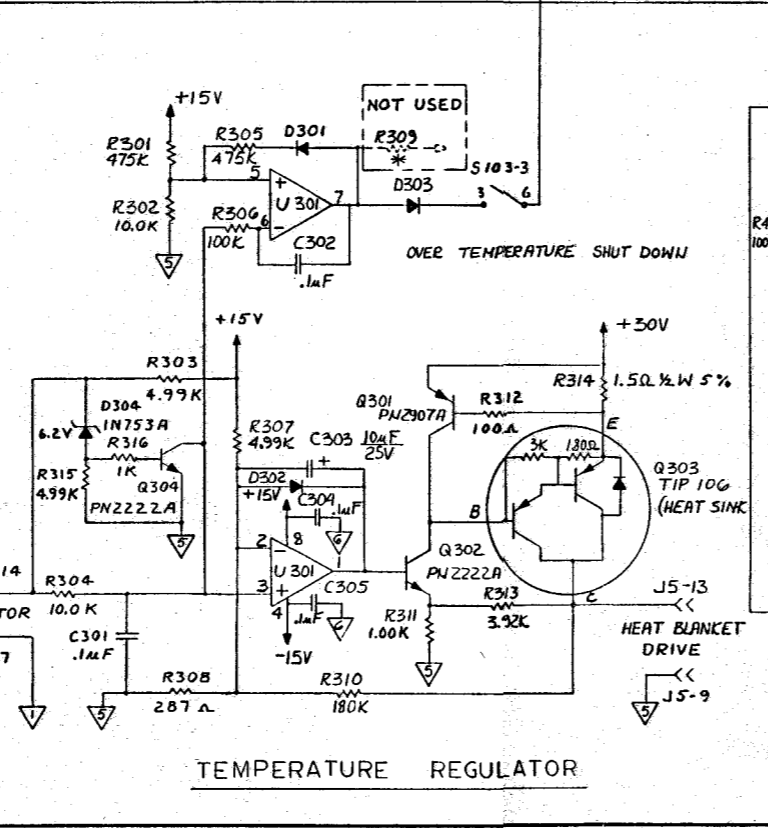
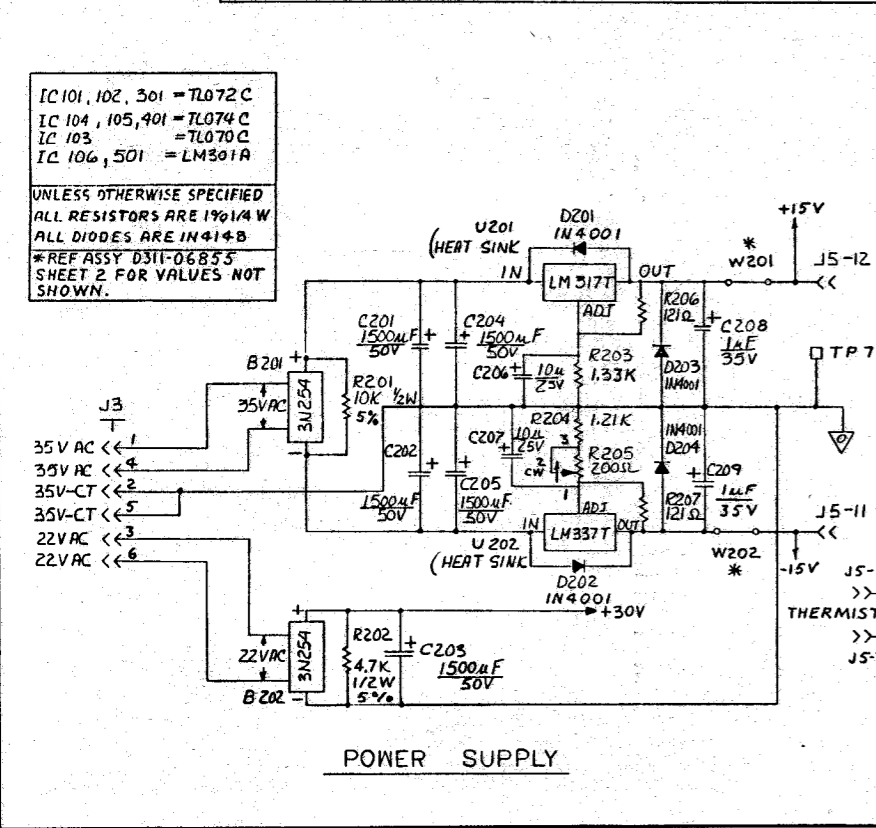
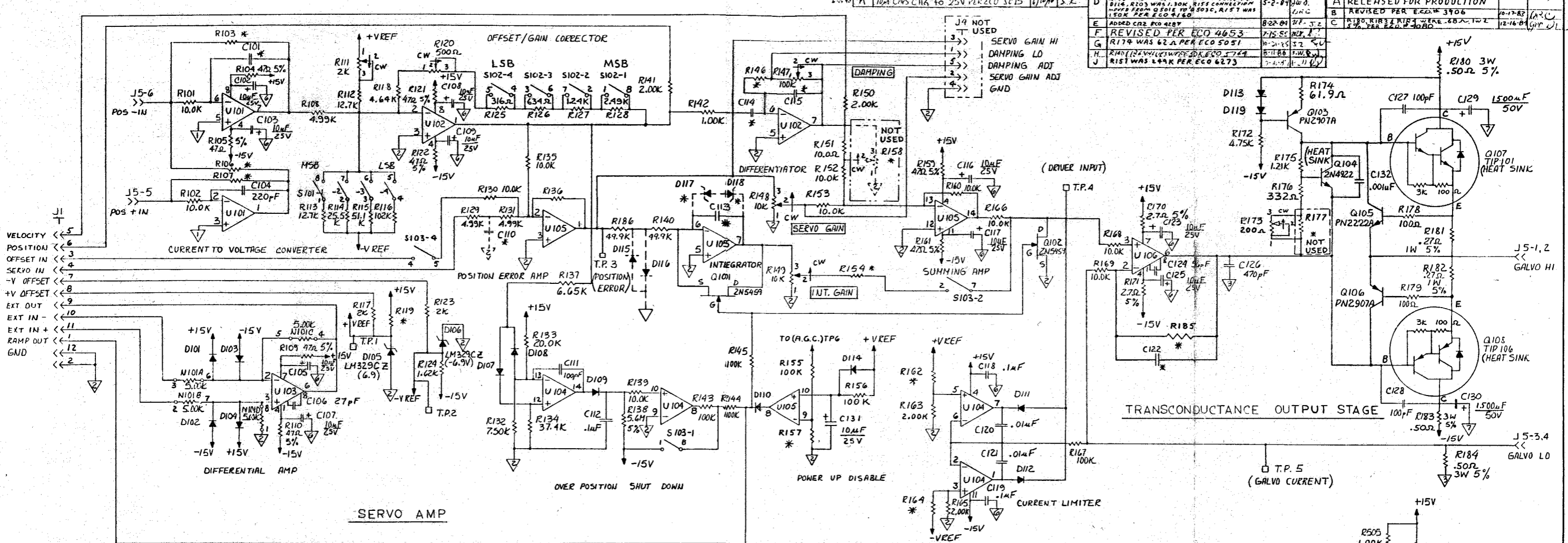

UNLESS OTHERWISE SPECIFIED DIMENSIONS ARE IN INCHES		SCALE	DATE
TOLERANCES	DECIMAL	1/16"	12-2-82
XXX ± .005	1/16"	1/32"	
XXX ± .001	1/32"	1/64"	
XXX ± .0005	1/64"	1/128"	
REMOVE ALL BURRS AND SHARP EDGES		CHECKED	
MATERIAL		APPROVED	
TREATMENT		APPROVED	
TITLE		USED ON	
SCHEMATIC A 660			
GENERAL SCANNING INCORPORATED WATERTOWN, MA.		SIZE	DRAWING NUMBER
		D	3SD-06856
		REV.	K

PROPERTY OF GENERAL SCANNING  
 This document is the property of General Scanning and is loaned to you for your use only. It is not to be distributed outside your organization. If you have any questions, please contact General Scanning at 1-800-368-7272.

REVISION	RECORD	DATE	APPROV.
A	RELEASED FOR PRODUCTION		
B	ADDED NOTE 5 PER ECO 3866		
C	DELETED R309 (CLIPS) PER ECO 3906	10-14-83	10/20
D	ADDED ITEM 18 PER ECO 4014	1-23-84	1/20
E	R185 WAS C122, ADDED D116, C131 & S103 PER ECO 4160	5-2-84	5/10
F	ADDED C122 PER ECO 4287	8-22-84	8/22
H	REVISED PER ECO 4653	7-15-85	7/15
G	DELETED R309, R310, R311, R312, R313, R314, R315, R316, R317, R318, R319, R320, R321, R322, R323, R324, R325, R326, R327, R328, R329, R330, R331, R332, R333, R334, R335, R336, R337, R338, R339, R340, R341, R342, R343, R344, R345, R346, R347, R348, R349, R350, R351, R352, R353, R354, R355, R356, R357, R358, R359, R360, R361, R362, R363, R364, R365, R366, R367, R368, R369, R370, R371, R372, R373, R374, R375, R376, R377, R378, R379, R380, R381, R382, R383, R384, R385, R386, R387, R388, R389, R390, R391, R392, R393, R394, R395, R396, R397, R398, R399, R400, R401, R402, R403, R404, R405, R406, R407, R408, R409, R410, R411, R412, R413, R414, R415, R416, R417, R418, R419, R420, R421, R422, R423, R424, R425, R426, R427, R428, R429, R430, R431, R432, R433, R434, R435, R436, R437, R438, R439, R440, R441, R442, R443, R444, R445, R446, R447, R448, R449, R450, R451, R452, R453, R454, R455, R456, R457, R458, R459, R460, R461, R462, R463, R464, R465, R466, R467, R468, R469, R470, R471, R472, R473, R474, R475, R476, R477, R478, R479, R480, R481, R482, R483, R484, R485, R486, R487, R488, R489, R490, R491, R492, R493, R494, R495, R496, R497, R498, R499, R500, R501, R502, R503, R504, R505, R506, R507, R508, R509, R510, R511, R512, R513, R514, R515, R516, R517, R518, R519, R520, R521, R522, R523, R524, R525, R526, R527, R528, R529, R530, R531, R532, R533, R534, R535, R536, R537, R538, R539, R540, R541, R542, R543, R544, R545, R546, R547, R548, R549, R550, R551, R552, R553, R554, R555, R556, R557, R558, R559, R560, R561, R562, R563, R564, R565, R566, R567, R568, R569, R570, R571, R572, R573, R574, R575, R576, R577, R578, R579, R580, R581, R582, R583, R584, R585, R586, R587, R588, R589, R590, R591, R592, R593, R594, R595, R596, R597, R598, R599, R600, R601, R602, R603, R604, R605, R606, R607, R608, R609, R610, R611, R612, R613, R614, R615, R616, R617, R618, R619, R620, R621, R622, R623, R624, R625, R626, R627, R628, R629, R630, R631, R632, R633, R634, R635, R636, R637, R638, R639, R640, R641, R642, R643, R644, R645, R646, R647, R648, R649, R650, R651, R652, R653, R654, R655, R656, R657, R658, R659, R660, R661, R662, R663, R664, R665, R666, R667, R668, R669, R670, R671, R672, R673, R674, R675, R676, R677, R678, R679, R680, R681, R682, R683, R684, R685, R686, R687, R688, R689, R690, R691, R692, R693, R694, R695, R696, R697, R698, R699, R700, R701, R702, R703, R704, R705, R706, R707, R708, R709, R710, R711, R712, R713, R714, R715, R716, R717, R718, R719, R720, R721, R722, R723, R724, R725, R726, R727, R728, R729, R730, R731, R732, R733, R734, R735, R736, R737, R738, R739, R740, R741, R742, R743, R744, R745, R746, R747, R748, R749, R750, R751, R752, R753, R754, R755, R756, R757, R758, R759, R760, R761, R762, R763, R764, R765, R766, R767, R768, R769, R770, R771, R772, R773, R774, R775, R776, R777, R778, R779, R780, R781, R782, R783, R784, R785, R786, R787, R788, R789, R790, R791, R792, R793, R794, R795, R796, R797, R798, R799, R800, R801, R802, R803, R804, R805, R806, R807, R808, R809, R810, R811, R812, R813, R814, R815, R816, R817, R818, R819, R820, R821, R822, R823, R824, R825, R826, R827, R828, R829, R830, R831, R832, R833, R834, R835, R836, R837, R838, R839, R840, R841, R842, R843, R844, R845, R846, R847, R848, R849, R850, R851, R852, R853, R854, R855, R856, R857, R858, R859, R860, R861, R862, R863, R864, R865, R866, R867, R868, R869, R870, R871, R872, R873, R874, R875, R876, R877, R878, R879, R880, R881, R882, R883, R884, R885, R886, R887, R888, R889, R890, R891, R892, R893, R894, R895, R896, R897, R898, R899, R900, R901, R902, R903, R904, R905, R906, R907, R908, R909, R910, R911, R912, R913, R914, R915, R916, R917, R918, R919, R920, R921, R922, R923, R924, R925, R926, R927, R928, R929, R930, R931, R932, R933, R934, R935, R936, R937, R938, R939, R940, R941, R942, R943, R944, R945, R946, R947, R948, R949, R950, R951, R952, R953, R954, R955, R956, R957, R958, R959, R960, R961, R962, R963, R964, R965, R966, R967, R968, R969, R970, R971, R972, R973, R974, R975, R976, R977, R978, R979, R980, R981, R982, R983, R984, R985, R986, R987, R988, R989, R990, R991, R992, R993, R994, R995, R996, R997, R998, R999, R1000		

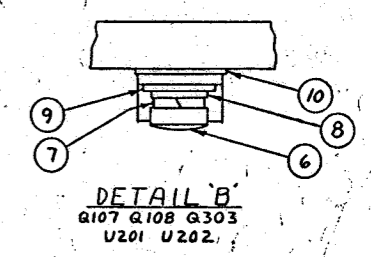
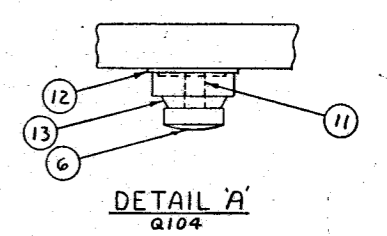
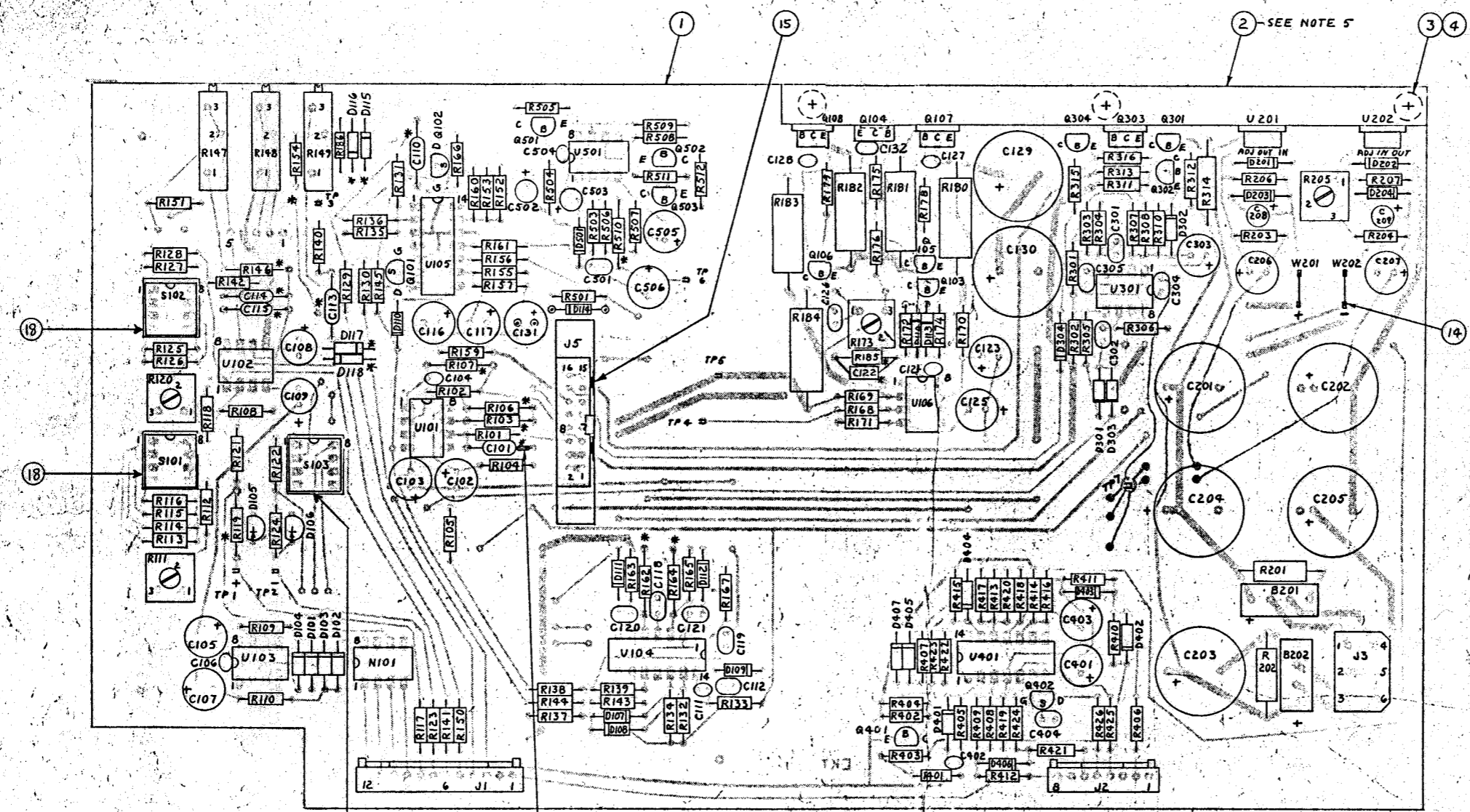

- NOTES:
1. REP. SCHEMATIC D35D-06856
  3. INSTALL ALL CAPACITORS WITH PLASTIC JACKETS AFTER WAVE SOLDERING & CLEANING.
  4. \* VARIABLE VALUE SEE MODEL
  5. HEAT SINK ITEM 2 TO BE MOUNTED FLUSH WITH OR SLIGHTLY PROTRUDING OVER OUTSIDE EDGE OF P.C. BOARD ITEM 1
  6. THERMAL COMPOUND REQUIRED ON ALL DEVICES.

UNLESS OTHERWISE SPECIFIED	SCALE	DATE	APPROV.
DIMENSIONS ARE IN INCHES	2X	2-22-83	
FRACTIONS ARE IN DECIMALS			
REMOVE ALL NUMBERS FROM DIMENSIONS			
MATERIAL	SEE P/L 000-8660		
TITLE	ASSY P.C. A660		
GENERAL SCANNING	WATERTOWN, MA.		
DRAWING NUMBER	D 311-06855		

REV	R	K	R	R	R	R	R	R	R	A						
DASH	1	2	3	4	5	6	7	8	9	10	11					
MODEL	AG60A	AG60B	AG60C	AG60D	AG60E	AG60F	AG60G	AG60H	AG60J	AG60K	AG60L	AG60M	AG60N	AG60P	AG60Q	AG60R
USED WITH	G120D G120DT	G120DC G120DCT	G138D G138DT	G220D G220DT	GF220D GF220DT	G325D G325DT	GF320D GF320DT		G350D G350DT		MILITARY G401					
C101	470 PF		470 PF	.001μF	.001μF	.001MF			.001MF		470 PF					
C110																
C113	.0033 MF		.0033μF	.0047μF	.0047μF	.015 MF			.015 MF		.0033μF					
C114	.0022 MF		.0022μF	.0082μF	.0082μF	.01MF			.015 MF		.0047μF					
C115	220 PF		220 PF	820 PF	.001μF	.001MF			.0015 MF							
C122					220 PF						100 PF					
R103	4.99 K 1%		2.67 K 1%	2.55 K 1%	4.99 K 1%	1.82 K 1%			909 Ω 1%		3.01 K 1%					
R106	4.99 K 1%		4.99 K 1%	4.99 K 1%	4.99 K 1%	4.99 K 1%			4.99 K 1%		4.99 K 1%					
R107	4.99 K 1%		4.99 K 1%	4.99 K 1%	4.99 K 1%	4.99 K 1%			4.99 K 1%		4.99 K 1%					
R119	619 Ω 1%		619 Ω 1%	619 Ω 1%	619 Ω 1%	619 Ω 1%			619 Ω 1%		619 Ω 1%					
R146	20.0 K 1%		20.0 K 1%	20.0 K 1%	0 Ω (BUS WIRE)	37.4 K 1%			37.4 K 1%		37.4 K 1%					
R154	100 K 1%		100 K 1%	100 K 1%	100 K 1%	100 K 1%			100 K 1%		100 K 1%					
R158																
R162	30.1 K 1%		22.1 K 1%	30.1 K 1%	30.1 K 1%	25.5 K 1%			25.5 K 1%		3.01 K 1%					
R164	30.1 K 1%		22.1 K 1%	30.1 K 1%	30.1 K 1%	25.5 K 1%			25.5 K 1%		3.01 K 1%					
R177																
R185	1 M 1%		1 M 1%	1 M 1%	1 M 1%	1 M 1%			1 M 1%		1 M 1%					
R510																
W201	USED		USED	USED	USED	USED			USED		USED					
W202	USED		USED	USED	USED	USED			USED		USED					
D115																
D116																
D117																
D118																
R157	332 K 1%		249 K 1%	249 K 1%	249 K 1%	249 K 1%			249 K 1%							
ORIGINAL PRODUCT	CX6120	CX6120C	CX6138	CX6220	CX6220F	CX6325	CX6320F		CX6350							

UNLESS OTHERWISE SPECIFIED DIMENSIONS ARE IN INCHES		SCALE	DATE
TOLERANCES	DECIMAL	ANGULAR	
	XX ± .01	3° - 90°	
	XXX ± .005		
REMOVE ALL BURRS AND SHARP EDGES	CHECKED	USED ON	
MATERIAL	APPROVED	TITLE	
TREATMENT	APPROVED	ASSY AG60	
GENERAL SCANNING INCORPORATED WATERTOWN, MA.		SIZE	DRAWING NUMBER
		D	311-06855
		REV	22A
		SHEET 2 OF 2	