

GSI Lumonics

XY10A Scan Head Hardware Manual

Analog Interface

**60 Fordham Road
Wilmington, MA 01887**

**GMAX™ SYSTEMS
MULTI-AXIS BEAM HANDLING**

TABLE OF CONTENTS

1. INTRODUCTION	1
1.1 Warranty.....	2
1.2 Customer Support	3
1.3 Unpacking	3
2. XY10A OVERVIEW (ANALOG INTERFACE)	5
2.1 Theory of Operation.....	5
2.2 General Description	6
2.3 Specifications.....	7
3. SAFETY AND WARNINGS	9
3.1 Laser Shutter Installation	11
3.2 Installation Safety Requirements	12
4. INSTALLATION	13
4.1 Handling the XY10A Scan Head Lens	13
4.2 Mounting the XY10A Scan Head	14
4.3 Interconnections	15
5. MAINTENANCE.....	17
5.1 Lens / Protection Glass Cleaning.....	17
5.1.1 Introduction.....	17
5.1.2 Basic Cleaning Procedure	17
5.1.2.1 Back-spatter / Burned-in Damage.....	18
5.2 Mirror	18
5.2.1 Cleaning Procedure	18
6. TROUBLESHOOTING	21
7. GLOSSARY (HPM SERIES)	23
8. APPENDIX A: Specifications	25
8.1 XY10A Scan Head.....	25
8.2 XY10A Scan Head Mirror	26
8.3 XY10A Scan Head Pin Configurations	27
8.4 Notes on Signal Definitions	28
8.4.1 AChannel Signals.....	28
8.4.2 Status Signals	28
8.5 Input Circuit Diagram of Analog Interface.....	29
9. APPENDIX B: Technical Outline Drawings	31

XY10A Scan Head Analog Interface Hardware Manual

1. INTRODUCTION

This manual details the instructions on how to install and operate hardware of the **XY10A Scan Head (Analog Interface)**. Included is information on setting up the hardware in preparation for your software commands, at which point you can refer to the proper software manual.

Be careful to observe the information in the Environmental Requirements section that alert you to the hazards and the laser beam path you can expect while running the **XY10A**.

The **XY10A** Scan Head is **extremely intricate**, and since it consists of the galvanometers that reflect the laser beam, it can be hazardous if certain precautions are not taken. Please be alert to the safety considerations and specific procedures regarding the **XY10A** Scan Head and the laser you are using.

Conventions

Throughout the manual you will see graphic icons representing pertinent information in the text. The purpose of these icons is to provide a visual convention to alert you of a stop in the flow of the manual, where an important note or safety hazard alert is posted.





NOTE is an important procedure you should be aware of before proceeding.

CAUTION alerts you of a potential danger to equipment or the user.

WARNING indicates an imminent danger to the user.

TIP and **REMINDER** are helpful hints to procedures listed in the text.

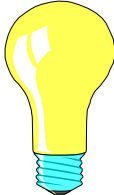
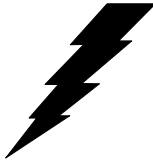
The conventions are listed as follows, showing both the text and the picture you will see.

NOTE	CAUTION	TIP	WARNING	REMINDER
				

GMAX, HC/2, HCI, PC-MARK MT, HPM and HPLK are trademarks of GSI Lumonics.

Microsoft, MS-DOS and Windows are registered trademarks of Microsoft Corporation. HP is a registered trademark of Hewlett-Packard Company.

1.1 Warranty

GSI Lumonics (GSLI) warrants this product to be free from defects in materials and workmanship for 12 months from the date of shipment. GSLI will, at its option, repair or replace the product if it is defective within the warranty period and returned, freight pre-paid, to a service center designated by GSLI.

GSI Lumonics requests that customers obtain a Return Authorization Number prior to returning units, and that they carefully pack units in their original packing or equivalent.

Under warranty, GSLI is not obligated to repair damage to any units resulting from the following conditions (customers are responsible for defining which conditions are applicable to their product):

- a) Personnel other than GSLI representatives attempting to repair or service the product.
- b) Improper use of the equipment.
- c) Connecting the product to incompatible equipment.
- d) Personnel other than GSLI representatives modifying the product.
- e) Scratches and chips on any optical surface after three weeks from the date of receipt.
- f) Damage to any optical surface from improper handling or cleaning procedures. This applies specifically to those items subjected to excess laser radiation, contaminated environments, extreme temperature or abrasive cleaning.

Customers assume all responsibility for maintaining a laser-safe working environment. OEM customers must assume all responsibility for **CDRH** (Center for Devices and Radiological Health) certification.



NOTE

There is no implied warranty of fitness for a particular purpose, and GSLI is not responsible for consequential damages. Individual components manufactured by GSLI or others may be covered by their own warranties. Refer to the appropriate manuals for this information.

1.2 Customer Support

GSI Lumonics has support services available to you concerning problems with either the product or manual you are using.

Before calling for assistance, please make sure you refer to any appropriate sections in the manual that may answer your questions. The “Technical Outline Drawings” in APPENDIX B may be particularly helpful. If you need further assistance:

The customer service personnel will be able to give you direct assistance and answers to your questions.



U.S. (Massachusetts):	978-661-4300 (in the U. S.) +01 978-661-4300 (outside the U. S)
Germany (Munich):	+49 89 899134-0
Italy (Monza):	+39 39 2025387
UK (Banbury):	+44 132-787-2424
Japan (Tokyo):	+81 3 3406 7990

... ask for the GMAX Customer Service Department

1.3 Unpacking

- a) CAREFULLY unpack the contents from the box.
- b) Save shipping container and packaging material in case you need to return unit for service.
- c) Check contents of the box against the packing list to assure all parts have been received.
- d) Inspect each item to assure it is not damaged.

2. XY10A OVERVIEW (ANALOG INTERFACE)

2.1 Theory of Operation

XY10A Scan Head (Analog Interface) is a multi-purpose-designed module. The module consists of 2 galvanometer scanners (X and Y), optics (flat field lens) and integrated driver electronics all enclosed in a black anodized aluminum case.

*X and Y Galvanometric
Scanners with a Flat
Field Lens*

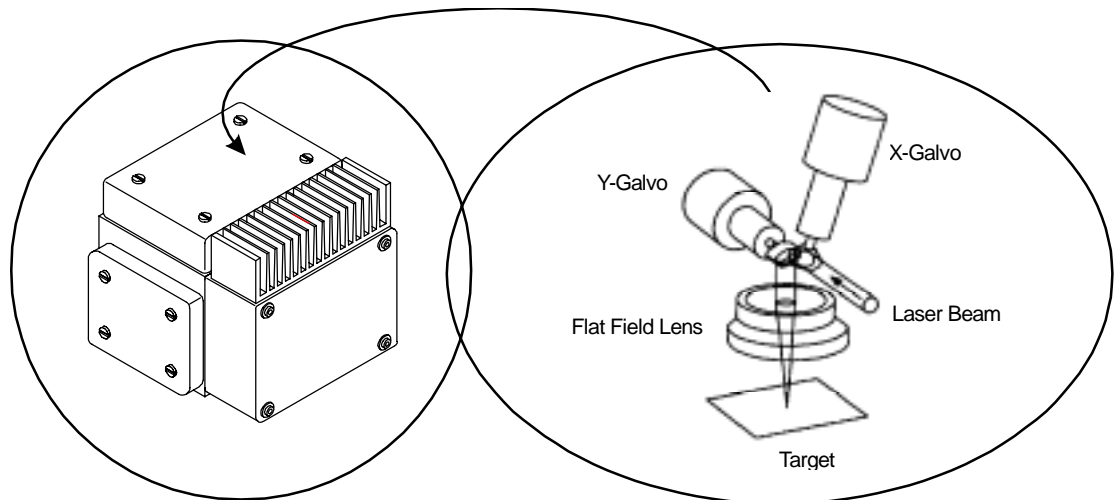

GSI Lumonics 2-mirror, 2-axis galvanometer Scan Heads provide the capability of deflecting optical beams in an XY manner for all possible laser applications. The synchronized actions of two galvanometer servo-controlled turning mirrors direct the laser beam to specific locations on a target material surface in both the X and Y directions.

2.2 General Description

The **XY10A Scan Head (Analog Interface)** is a basic building block for the construction of a laser beam positioning system, It is intended for use by OEM customers, integrators, and sophisticated end-users.

The 7.5 mA analog interface has separate signal inputs for X- and Y-axis, input gain and offset pots for each channel. Status signals provide indications of fault and position acknowledge.

- ±15 V Input: 25 pin D sub connector female, mounted on the **XY10A** Scan Head
- Interface Connector: 9 pin D sub connector female, mounted on the **XY10A** Scan Head

GSI Lumonics provides the following items that make up the XY10A Scan Head package:

- **XY10A** Scan Head with 2 galvanometer scanners, optics and integrated driver electronics.
- Documentation.

The Customer must provide:

- A laser.
- A computer
- A method of mounting the **XY10A** Scan Head
- An analog interface cable
- Power supply with the following specifications:

Power Supply Specifications

Voltage V1/V2	±15 V +5%-0%
Current	2A
Ripple	≤ 0.2%
Noise	≤ 0.5% DC to 30MHz



NOTE

- The V2 input can be used as a sense wire by shorting the pin 13 to 12 and 10 to 9 on the 25 pin male connector (customer side). Else, it's used as the main voltage input to the power end-stage.
- A sense wire is not needed when the distance is under 3m to the **XY10A** Scan Head.
- The supplies need to be capable of supplying the necessary current for the galvos, the heater systems and the electronics.

2.3 Specifications

Environmental Requirements

Storage Temperature:	-10°C to +60°C
Minimum Operation Temperature:	+15°C
Maximum Operating Temperature:	+34°C
Humidity:	Non-condensing

XY10A Scan Head

Specifications and Pin Configurations are located in “APPENDIX A: Specifications”.

Mirrors

Specifications are located in “APPENDIX A: Specifications”.

3. SAFETY AND WARNINGS

The United States Food and Drug Administration, through the Center for Devices and Radiological Health (CDRH), has promulgated regulations (21 CFR parts 1000 and 1040) controlling the safety of lasers and laser products for sale or manufacture in the United States. GSI Lumonics **XY Scan Heads** are regulated by the CDRH.

This section is a guide to the specific areas of this product and to the manual(s). Pay particular attention to CDRH compliance information.

*User
Responsibilities*

GSI Lumonics **XY Scan Head** are designed to provide maximum flexibility and ease of use. Such a design inherently requires the user to assure the overall safety of the configuration in use.

It is the user's responsibility to insure that:

- 1) Only lasers certified to comply with CDRH regulations are used with GSI Lumonics **XY Scan Heads**.
- 2) Certified lasers contain features to assist in their safe usage. These protective features and the protective features within the GSI Lumonics **XY Scan Heads** should not be defeated.



CAUTION

Prior to operating any configuration of the GSI Lumonics XY Scan Heads, you must make a thorough analysis of system safety. Key information for this purpose is contained in this manual. You would thoroughly familiarize yourself with all this information before proceeding.

Laser Hazard Analysis

A full description of laser hazard analysis is beyond the scope of this manual. A good technical survey of laser safety requirements can be found in **ANSI Z136.1, "American National Standard for the Safe Use of Lasers"**. This is available from:

*American National Standards Institute, Inc.
1430 Broadway
New York, New York 10018*

Among the many other sources of laser safety information, the following institution offers several excellent publications.

*The Laser Institute of America
5151 Monroe Street, Suite 118W
Toledo, Ohio 43623*

Your Laser Safety Officer or a competent specialist in this field should make final analysis of all safety features.

The first consideration in a safety analysis is the laser mated to the GSI Lumonics **XY Scan Head**. The Laser Class label that is on the device roughly indicates the hazard level of the laser. A brief description of the radiation classes is shown in the following table.

Note that, besides radiation, lasers may present other hazards, e.g.; electric shock or creation of poisonous fumes.

Classes and Characteristics of Lasers

LASER CLASS	DESCRIPTION
Class I	Lasers are not considered to be hazardous.
Class IIa	Lasers are hazardous if viewed for periods greater than one thousand seconds.
Class II	Lasers are chronic viewing hazards.
Class IIIa	Lasers may represent acute, intrabeam viewing or chronic or acute viewing hazards when viewed with optical instruments.
Class IIIb	Lasers are an acute hazard to skin and eyes from direct radiation.
Class IV	Lasers are an acute hazard to skin and eyes from direct or scattered radiation.



CAUTION

Do not use equipment outside of these ranges, as additional hazards may result.

Because we do not determine the laser used with our product, all GSI Lumonics end-user **XY Scan Heads** are labeled at the highest hazard level (Class IV). You should obtain information on output power or energy, wavelength(s) of output, duration of pulse, beam size and beam divergence from the manufacturer of the laser you are using.

The wavelength and power of the laser actually used should be written on the warning logo type label, Position 2. (See Section page 33699 and 33700 of the Federal Register, Appendix B). Be sure to use permanent, indelible ink.

Class IV Warning Label

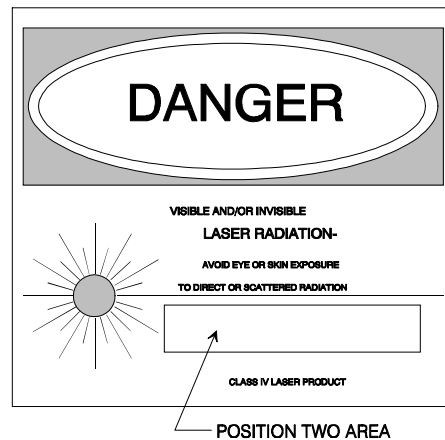

The Federal Register Rules and Regulations, Vol. 50, No. 161, dated Tuesday, August 20, 1985, contains the performance standards adopted by the Food and Drug Administration (FDA) which gives detailed information regarding the determination of laser classification and labeling. The ANSI and the FDA classifications are not the same. For purposes of labeling, use only the FDA classifications. If your laser falls in a classification below Class 4, replace the warning label type with the correct label and appropriate classification. The factory provides alternate labels upon request.



REMINDER

The GSI Lumonics **XY Scan Heads** provide you with the ability to aim the laser beam over a roughly pyramidal volume. The divergence of the focused beam beyond the focal point, which is a function of the lenses selected and their position, can cause radiation to exit the pyramid. When analyzing safety, you must consider all regions within this aiming pyramid, the divergent beam, and the effects of all focal possibilities in the zone of hazard. Reflections must also be considered.

3.1 Laser Shutter Installation



The laser attenuator (shutter) is not included with the **XY Scan Head**. Because each laser is unique, it is the user's responsibility to insure that such a device is incorporated in the installation in conformance with CFR regulations (1040.10[f][6]), which reads as follows:
 A beam attenuator is required on Class II, IIIa, IIIb and IV laser systems. The beam attenuator is a mechanical or electrical device such as a shutter or attenuator that blocks emission. The beam attenuator blocks bodily access to laser radiation above Class I limits without the need to turn off the laser. The beam attenuator must be available for use at all times during operation. Power switches and key controls do not satisfy the attenuator requirement.

Laser Shutter Location Example in a HPLK System

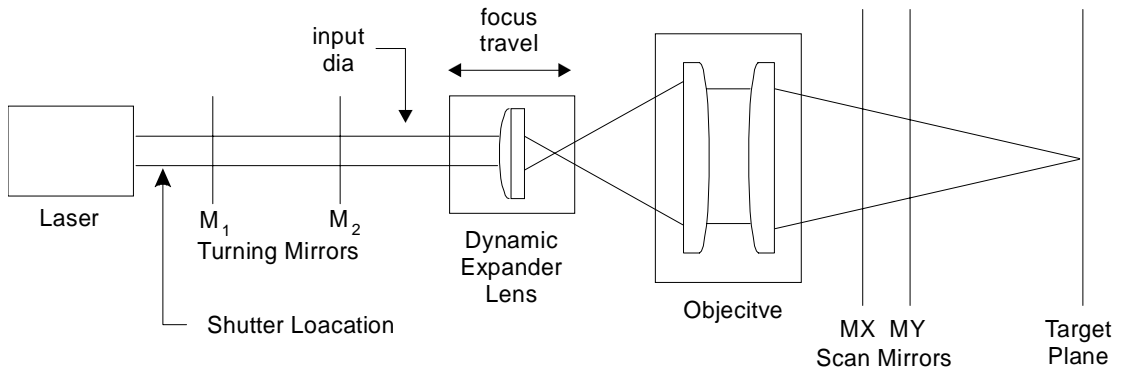

The beam shutter should be installed between the laser head and the Scan Head. The following figure shows the recommended location of the shutter.

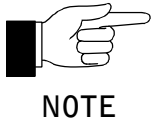

We strongly recommend that you specify a laser with a vendor-supplied shutter mechanism. If this is not possible, consult the laser vendor to design a proper safety shutter.

Laser Scanner Hazard Zones of an HPM Scan Head

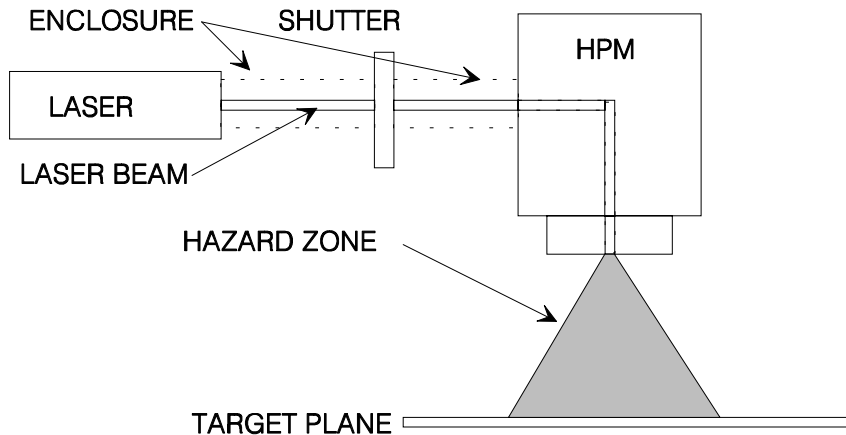

The figure shows the laser's internal and external optical path towards the target plane, specifically where the hazard zones are located as the optical beam passes through as **HPM Scan Head**.

3.2 Installation Safety Requirements

Because of the possible hazard increase of scanning stopping or slowing to an unsafe velocity, it is required that the controller software shuts down the laser power (a scanning safeguard).

In all cases, we recommend that you fully enclose and interlock the zone of hazard for your application to prevent possible opening while the laser is energized. When laser radiation exceeding Class 1 levels may exit the enclosure, you must have suitable protection for eyes available.



NOTE

At no time should you stare into the beam, place any parts of your body in the beam path, or expose yourself to reflections of powerful beams. You should use only a Class 1 HeNe Laser for alignment. If this is not possible, you should use the available laser's lowest power setting and remote beam sensing technique.



CAUTION

Using optical instruments with this product increases eye hazard.

Additional Safety requirements may be applicable during initial alignment of the optical system. Refer to Section, "Safety and Warnings", Section 3.

GSI Lumonics XY Scan Heads are labeled in conformance to the requirements of 21 CFR parts 1000 and 1040.

4. INSTALLATION

Installation Safety Requirements



WARNING

We recommend that you fully enclose and interlock the zone of hazard for your application to prevent possible opening while the laser is energized. If laser radiation exceeding Class 1 levels may exit the enclosure, you must have available suitable protection for your eyes.

At no time should you stare into the beam, place any parts of your body in the beam path, or expose yourself to reflections of powerful beams. You should use only a class I HeNe laser for alignment. If this is not possible, you should use the available laser's lowest power setting and remote beam sensing technique. Using optical instruments with this product increases eye hazard.

Additional Safety requirements may be applicable during initial alignment of the optical system. See the next section for specific safety information. GSI Lumonics **XY10A** Scan Heads are labeled in conformance to the requirements of 21 CFR parts 1000 and 1040.

4.1 Handling the XY10A Scan Head Lens

If you have not purchased a lens with your **XY10A**, and you are installing your own lens, or you are removing a lens, follow the steps outlined below for handling and installing a lens. .

Lens Mounting

YAG Lens Example

(Complete Assembly)

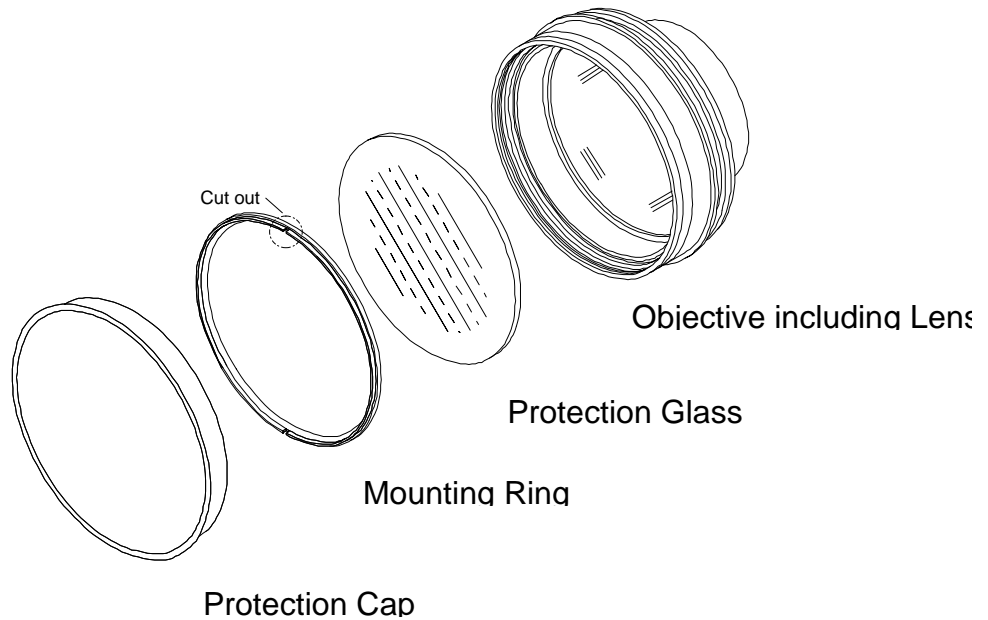

CAUTION

Make sure that the laser is off before performing any inspections! Wear finger cots or cotton gloves when handling optics for inspection.

To Install a Lens:

- 1) Before installing a lens onto the Scan Head, visually inspect the lens surface for any evidence of damage, i.e.; cracked lens, cracks on the edges of the lens, scratches on the lens surface.
- 2) If the lens is dirty, clean the lens per the lens cleaning instructions in the **MAINTENANCE**. Do not rest any objects on top of the lens as this may result in damaging the lens.
- 3) If there is a protection glass, make sure it is clean, and then place it over the front of the lens.
Screw the Mounting Ring into the lens flange until it is tight over the Protection Glass.
Hand-fit lens protection cap onto the lens assembly.
- 4) The lens assembly is screwed into the Scan Head. Carefully and securely mount the lens to the **XY10A** Scan Head. (**DON'T CROSS-THREAD THE LENS ASSEMBLY**). The lens should be screwed on completely.

To Remove a Lens:

Reverse the above procedure.

4.2 Mounting the XY10A Scan Head

Scan Head Outline

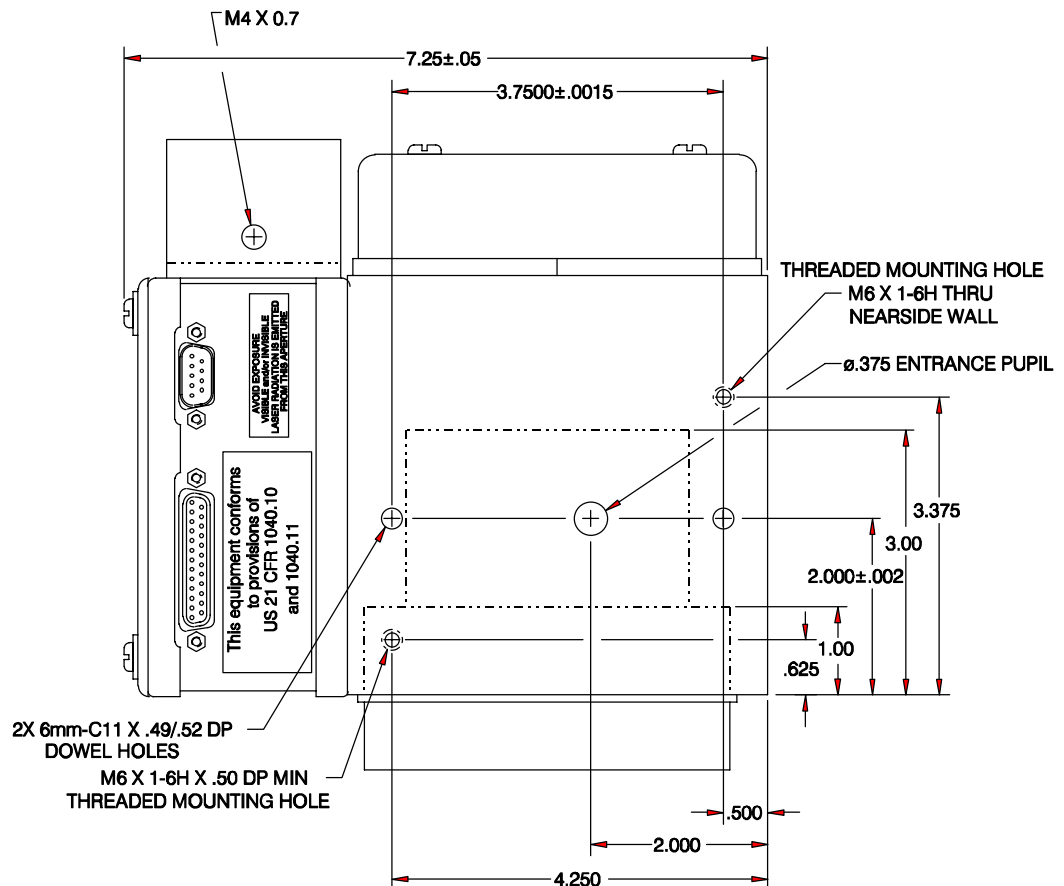

XY10A Mounting

- 1) The Scan Head requires a mounting flange that will match the mounting pins and holes on the **Beam Input** side of the assembly. The previous figure and the outline drawings, in Appendix C, can be used to determine the dimensions for manufacturing a mounting flange.
- 2) Line up the **XY10A** Scan Head module dowel holes with the dowel pins, which protrude from your mounting flange.
- 3) Install the **XY10A** Scan Head module onto the pins.
- 4) Insert two M6 size buttonhead screws into the holes of the mounting flange. The screw length should be long enough to provide three or more full turns into the tapped holes.
- 5) Using an Allen wrench, tighten the two screws. Alternate tightening the two screws so that the **XY10A** Scan Head comes together evenly with the mounting flange.

4.3 Interconnections

The connection scheme consists of two sets of differential current drivers at the computer-chassis and receivers at the **XY10A** Scan Head (Analog Interface). The scheme will allow transmission to the **XY10A** Scan Head over a distance of at least 10 feet (3 meter). The connector on the **XY10A** Scan Head is a 9 pin D-type connector. The cable can consist of twisted pair cable, which carries the signal in and out of the **XY10A** Scan Head.

5. MAINTENANCE

*Cleaning the XY10A
Scan Head*

The XY10A Scan Head assembly is sealed. The housing can be cleaned with a slightly dampened cloth. If a cleaning agent is necessary, use only a small quantity of non-aggressive cleanser (e.g. soap).

5.1 Lens / Protection Glass Cleaning

*Cleaning the Lens /
Protection Glass*

Special care should be exercised in cleaning a lens that does not have a protection window

5.1.1 Introduction

Optical materials and coatings are relatively soft materials and incorrect cleaning techniques can lead to surface damage and drastically reduced component lifetime.

Surface contamination can be of different kinds:

- Dust, grease and other air-borne particles.
- Products from the laser process - back spatter or burned-in particles.
- Organic contamination caused by talking, coughing or sneezing near the exposed optical surface.

The primary goal is to avoid any contamination by appropriate protection of the exposed optics!

The basic cleaning technique described here is intended to help prolong the component lifetime by minimizing surface damage during the cleaning process.



CAUTION

Not following this technique can cause severe damage to the optical components.

5.1.2 Basic Cleaning Procedure

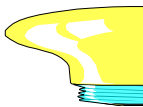

TIP

Optical components should always be handled using suitable gloves, or finger-cots, in order to avoid finger prints.

1. Surface dust and loose particles must be blown from the component using an air bulb, ideally one with a non-return valve.
2. Always use cloth or cotton buds which are moistened with **pure** acetone. Never use cleaning materials, which are dry.
3. Use a soft, lint-free lens cloth. The cloth has to be moistened with pure acetone, laid gently on one edge of the component and drawn in a continuous movement to the opposite edge.

DO NOT APPLY PRESSURE. DO NOT RUB!



CAUTION

Rubbing may cause permanent surface marks.

4. Blow away residue liquid in one direction with an air bulb.
5. Make sure that no visual contaminants remain on the optical surface.
6. Stubborn stuck-on particles may require an attempt to dislodge them by the local application of a cotton bud moistened with pure acetone.
7. Finish off per (3) above.
8. Organic contamination cannot usually be removed using solvents such as acetone. The residue should be removed using distilled water and a lens cloth prior to finishing per (3) above.

5.1.2.1 Back-spatter / Burned-in Damage

Some forms of back-spatter can be reduced or removed using the basic cleaning process.

In general, however, metallic back-spatter or laser-burned-in damage cannot be removed by cleaning.

If the extent of the contamination is sufficient to cause process problems (e.g.: thermal lensing), then consideration should be given to replacement of the contaminated component.

5.2 Mirror



CAUTION

Never touch the coating of the mirror to avoid any damages on the surface.

There are times, however, when cleaning the mirror becomes a necessity. Follow exactly the next section "Cleaning Procedure".

5.2.1 Cleaning Procedure

Although the user can replace the mirrors, we do **not recommend** you do so. Furthermore, **GSI Lumonics does not recommend cleaning front surface mirrors.** Mirrors damaged by cleaning are not included under the warranty. The surface of these mirrors damages easily. It is difficult to prevent hard dust particles from being entrained in the process and causing scratches. In many cases, small defects in the mirror's surface may be less harmful than the surface damage resulting from continued cleaning. It requires special equipment typically not available to customers.

There are times, however, when cleaning the mirror becomes a necessity, e.g. stains such as fingerprints must be removed immediately to prevent permanent etching of the reflective surface. The information below includes general recommendations for those special occasions when mirrors must be cleaned.

Remove lint from mirrors with a jet of low-pressure clean air. Blowing on front surface of mirror deposit moisture that may stain the finish.

Removing Dust

Removing Stains

A thin overcoating of silicon monoxide protects most mirrors from oxidation. Like many optical coatings, it is easily damaged when attempts are made to clean the mirror surface with a dry tissue.

The safest method of cleaning is to place a piece of lens tissue on the mirror surface and wet it with reagent grade (highly pure) alcohol or acetone (If you use acetone, take precautions regarding possible health and fire hazards). Grasp an overhanging corner of the tissue and gently agitate it several times, then slide the tissue off. This should remove the problem blemishes.



CAUTION

Do not let solvent enter the bounding zone of the mirror.



NOTE

Note that the mirror is not rubbed.

If the mirror surface is still contaminated, use a highly pure solvent such as alcohol or acetone and generously wet the mirror surface with a **sterile** cotton swab or lens tissue. Gently wipe the dirty areas. Turn your cotton swab or tissue with each stroke so that a clean area is exposed.



CAUTION

Do not let solvent enter the scanner bearings. When wetting the mirror's surface, hold the scanner at an angle so that the liquid does not wet the scanner. If any solvent is found in the bearings of the scanner, the warranty is voided.

6. TROUBLESHOOTING

If you encounter problems with your **XY10A Scan Head (Analog Interface)**, you can check the following matrix. If you cannot solve the problem, contact **GSI Lumonics** for further assistance.

PROBLEM	PROBABLE CAUSE	POSSIBLE SOLUTION
1. Decrease in marking quality.	1. Dirty protection glass.	1. Clean glass per instructions in Maintenance Section.
	2. Drop in output power.	1. Check laser power.
2. Laser will not mark when ordered by computer.	1. Laser modulation malfunction.	1. Check connections between laser controller and laser.
	2. No power to galvanometers.	1. Check power connections to scanning head.

7. GLOSSARY (HPM SERIES)

- Flat Field Lens:* A wavelength specific lens focuses the laser to a small spot and maintains this spot size over the entire target field.
- Galvanometer:* A scanner with limited rotation magnetic torque motor with position feedback. The galvanometer (galvo) rotates a mirror to direct the laser beam.
- HC/2:* A PC based board that provides the hardware link between your PC and the XY Industrial Scan Head. I/O for laser control and parts handling are additional features. The HC/2 is fully compatible with PC-MARM MT (multitasking) software.
- HPGL:* HP® Graphics Language, a graphics format which PC-MARK MT can translate into vector data for scanning.
- HPM:* (High Performance Modules) Complete beam position packages consisting of the XY Industrial Scan Head, PC resident HC/2 card, PC-MARK MT software and interconnects.
- I/O-2:* An add-on board available as an option to the HC/2 card. Features include opto-isolated programmable I/O ports, analog laser power control and first pulse suppression.
- PC-MARK MT:* (multitasking) A powerful front-end macro command language. PC-MARK MT accepts application commands to place text and graphics in the marking field and translates them into the appropriate lists of vectors. Users may also write their own PC-MARK MT programs in any one of many popular software languages. MMCL is utilized as the link to the HC/2 card.
- JOB EDITOR:* A menu-driven application program of PC-MARK MT that provides an extensive graphics user interface and file management. It allows the user to manipulate HPGL based graphics with an accurate real preview of one's job.

8. APPENDIX A: Specifications

8.1 XY10A Scan Head

Laser Type	YAG			CO ₂	
	1,064 nm	1,064 nm	1,064 nm	10,600 nm	10,600 nm
Wavelength	1,064 nm	1,064 nm	1,064 nm	10,600 nm	10,600 nm
Objective (f in mm)	f = 100	f = 163	f = 254	f = 100	f = 200
Standard Field Size (mm ²)	55x55	115x115	180x180	60x60	120x120
Maximum Practical Field Size (mm ²) ¹	70x70	115x115	180x180	60x60	120x120
Spot Size TEM ₀₀ (μm)	~23	~31	~41	~230	~380
Working Distance (mm) ²	108	207	338	76	190
Resolution (μm) ³	< 4	< 7	< 11	< 4	< 8
Writing Speed (m/s) ⁴	> 1.8	> 3	> 4.5	> 1.8	> 3.5
Uncalibrated Non-Linearity (maximum %) ⁵	±0.6	±0.6	±0.6	±1.0	±1.0
Temperature Drift (maximum μm/°C) ⁶	7.7	12.7	19.8	6.6	13.2
Aperture (mm)	9.5	9.5	9.5	9.5	9.5
Scan Angle (maximum)	±20°	±20°	±20°	±20°	±20°
Power Capability, cw (W/cm ²) ⁷	500	500	500	500	500
Power Capability, 100 ns pulsed (MW/cm ²)	100	100	100	400	400
Protection Glass	yes	yes	yes	none	none
Scan Head Size ⁸ (height x length x width in mm)	175x171x183	175x184x183	175x197x183	175x172x183	175x172x183
Weight (kg) ⁹	5.0	5.0	5.5	5.0	5.0
Surface Finish	black anodized	black anodized	black anodized	black anodized	black anodized
Protection	IP40+	IP40+	IP40+	IP40+	IP40+

¹ Some beam clipping can occur.

² Distance between edge of head and working field.

³ Better than 2 bit in a 16-bit system (±0.003 %).

⁴ Actual writing speed depends on accuracy and feature sizes (jump speeds can be much higher).

⁵ Includes lens distortion; non-linearity can be improved by an order of magnitude by using individual calibration methods in software.

⁶ Temperature drift is maximum 0.011 %/°C and typ. 0.008 %/°C.

⁷ Determined by the mirror specifications.

⁸ Scan head basic dimensions without the lenses: Height = 175 mm, Length = 162 mm, Width = 183 mm.

⁹ Scan Head weight without lens: 4.5 kg.

Non-lens mirror configuration options: Argon, Argon (HP), UV and Visible.

8.2 XY10A Scan Head Mirror

	LASER TYPE					
	YAG	CO2	ARGON	ARGON (HP)	UV	VISIBLE
Wavelength	1,064 nm	10,600 nm	488-514 nm	488-514 nm	325-360 nm	450-700 nm
Coating	Dielectric	Dielectric on Metal	Dielectric	Dielectric	Dielectric	Durable Ag
Reflection (min.) @ Wavelength (nm)	99.5% @ 1,064 80.0% @ 450-650	99.5%	98.0% @ 480-514 50.0% @ 633	99.5%	98.0% @ 325-350 95.0% @ 350-360 45.0% @ 633	96.0%
Flatness @ 633 nm	$\lambda/4$	$\lambda/4$	$\lambda/4$	$\lambda/4$	$\lambda/4$	$\lambda/4$
Power Capability, cw (W/cm²)	500	500	100	5 MW/cm ²		10
Power Capability, 100 ns pulsed (MW/cm²)	100	400	80	2 GW/cm ² (10 ns pulsed)		N/A
Surface Quality (Scratch/Dig)	40/20	40/20	40/20	40/20	40/20	40/20

See your GSI Lumonics sales representative for more details.

8.3 XY10A Scan Head Pin Configurations

The D-type connector has 25 pins carrying power to the of **XY10A Scan Head (Analog Interface)**. The following pin configuration is used:

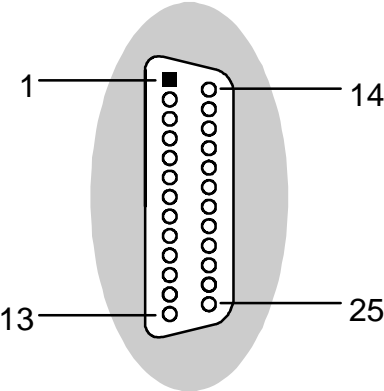
INTERFACE	PIN	ASSIGNMENT
 <p>25 Pin D-Sub female connector</p>	1	
	14	
	2	
	15	
	3	
	16	
	4	
	17	
	5	
	18	
	6	
	19	
	7	
	20	
	8	
	21	
	9	+ V1 (+15 V)
	22	+ V1 (+15 V)
	10	+ V2 (+15 V)
	23	Ground
	11	Ground
	24	Ground
	12	- V2 (-15 V)
	25	- V1 (-15 V)
	13	- V1 (-15 V)

The D-type connector has 9 pins carrying the signal, in both direction, to the of **XY10A Scan Head (Analog Interface)**. The following pin configuration is used:

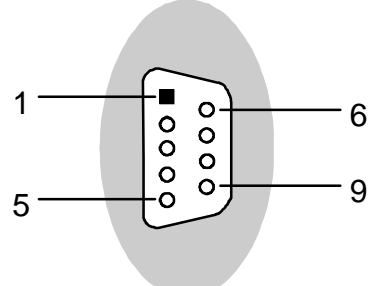
INTERFACE	PIN	ASSIGNMENT
 <p>9 Pin D-Sub female connector</p>	1	ACHANNELX +
	6	ACHANNELX -
	2	ACHANNELY +
	7	ACHANNELY -
	3	Ground
	8	Ground
	4	ERROR
	9	OPT. INPUT +24V
	5	/POSACK

The following signals control communication remotely:

- (i) ACHANNEL1 differential analog current causing deflection in (typically) X-axis.

- (ii) ACHANNEL2 differential analog current causing deflection in (typically) Y-axis.

The following signals allow information to be sent remotely:

- (iii)/POSACK O.C. TTL signal which goes to 0 V when both channels settled.
- (iv) ERROR O.C. TTL signal which indicates general system (temperature and power-status)

8.4 Notes on Signal Definitions

8.4.1 AChannel Signals

ACHANNELn + and ACHANNELn - are complimentary current signals. The sensitivity is such that a complimentary current of 7.5 mA will cause a deflection of 20° optical.

The direction of the signals is defined as follows:

Projection Field

9	8	7
6	5	4
3	2	1

CURRENT				POSITION WITHIN FIELD
ACHANNEL1+	ACHANNEL1-	ACHANNEL2+	ACHANNEL2-	
-7.5mA	+7.5mA	-7.5mA	+7.5mA	1
0	0	-7.5mA	+7.5mA	2
+7.5mA	-7.5mA	-7.5mA	+7.5mA	3
-7.5mA	+7.5mA	0	0	4
0	0	0	0	5
+7.5mA	-7.5mA	0	0	6
-7.5mA	+7.5mA	+7.5mA	-7.5mA	7
0	0	+7.5mA	-7.5mA	8
+7.5mA	-7.5mA	+7.5mA	-7.5mA	9

8.4.2 Status Signals

These signals are single ended and driven by open collector TTL (high voltage) gates. The lines will be pulled up at the remote Head to +5 V using a 1.2 k resistor. No attempt will be made to condition the signals before they are sent (e.g. no de-bouncing or filtering). The receiver circuitry should ensure that adequate thresholding is provided against D.C. offsets and noise and also that the error input (at least) is biased so that the removal of the cable causes an error indication.

8.5 Input Circuit Diagram of Analog Interface

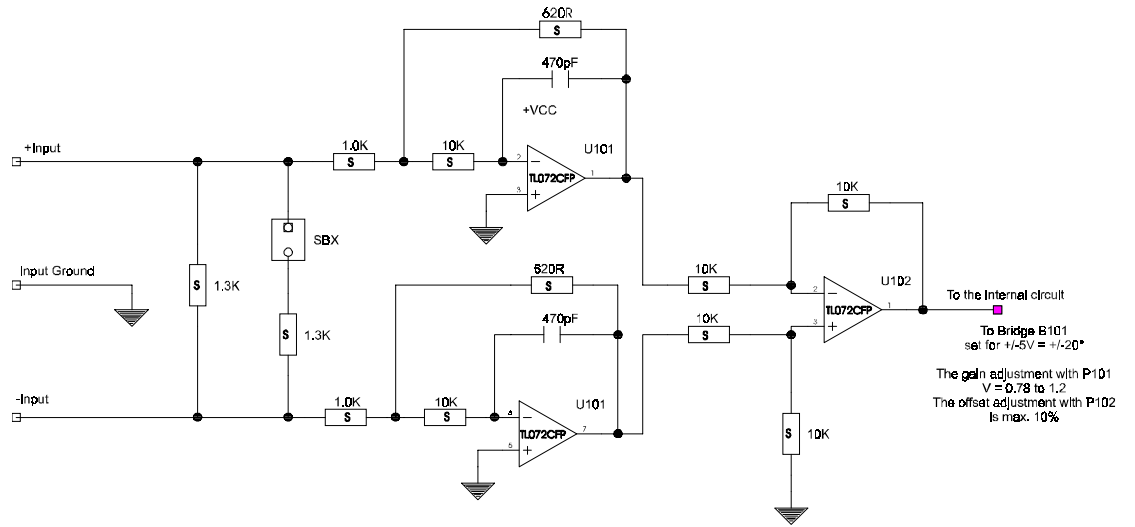

9. APPENDIX B: Technical Outline Drawings

This Appendix includes the following outline drawings:

DRAWING TITLE	DRAWING NUMBER
OUTLINE, XY10A W/O MOUNTING RING OR LENS	ECD-13734
OUTLINE, XY10A f/100 YAG	ECD-16825
OUTLINE, XY10A f/163 YAG	ECD-14654
OUTLINE, XY10A f/254 YAG	ECD-14862
OUTLINE, XY10A f/100 AND f/200 CO ₂	ECD-14656

PROPERTY OF C&L LUMONICS
 THIS DRAWING IS THE PROPERTY OF C&L LUMONICS. IT IS TO BE USED ONLY FOR THE PROJECT AND QUANTITIES SPECIFIED THEREON. IT IS NOT TO BE REPRODUCED, COPIED, OR TRANSMITTED IN ANY FORM OR BY ANY MEANS, ELECTRONIC OR MECHANICAL, INCLUDING PHOTOCOPYING, RECORDING, OR BY ANY INFORMATION STORAGE AND RETRIEVAL SYSTEM, WITHOUT THE WRITTEN PERMISSION OF C&L LUMONICS.

SYN	REVISION	REASON	DATE	APPROV.
1	RELEASED TO PRE-PRODUCTION			
A	PER ECN-8778			
B	REV. FEB. ECD-8457		11/79	G.P.
B	REV. FEB. ECD-8457			

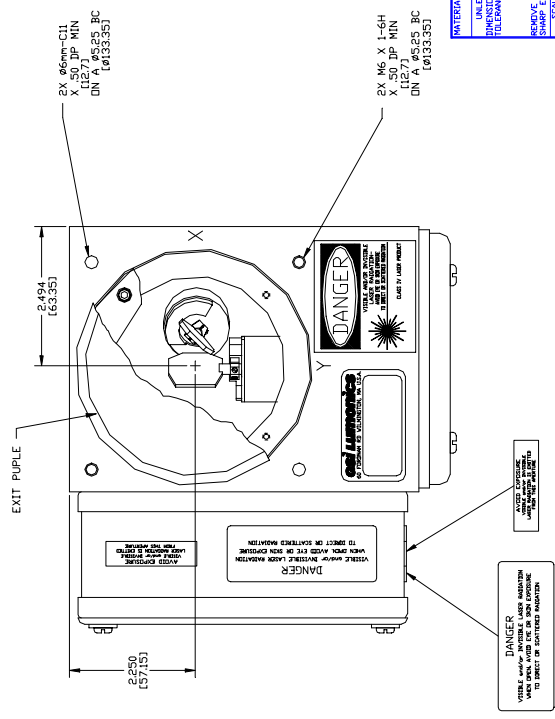
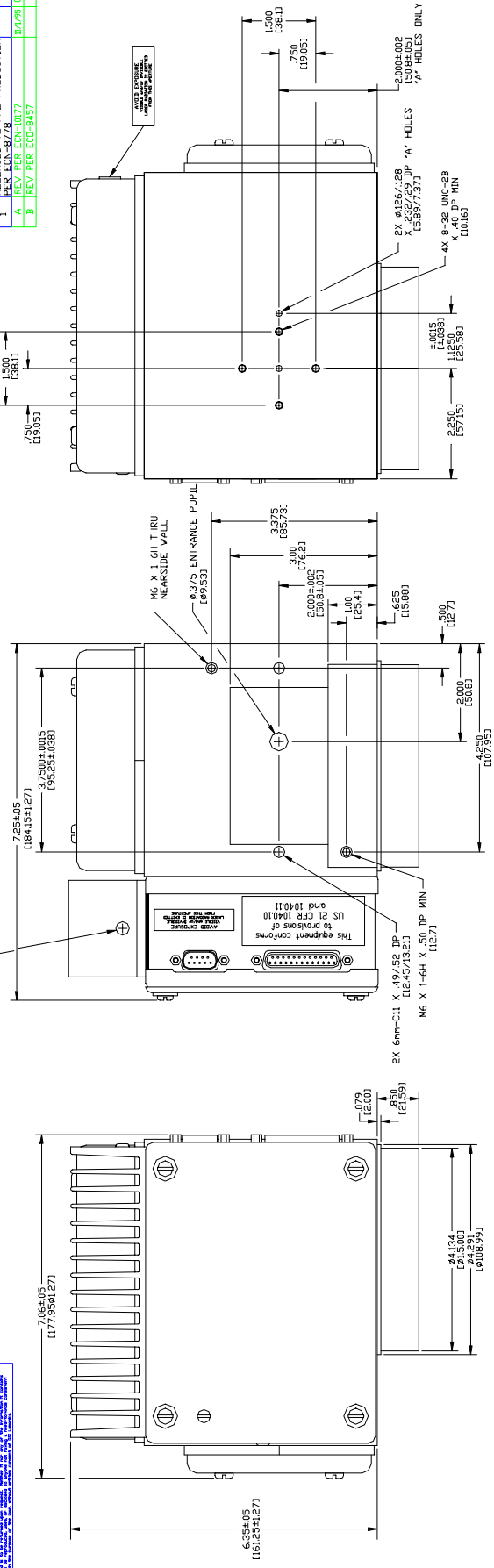

MATERIAL	TREATMENT	FUNCTION	NAME	DATE	CAD FILE NO.	ECN NO.	REV.	
UNLESS SPECIFIED DIMENSIONS ARE IN INCHES TOLERANCES ARE AS SHOWN		DRAWN	P. MACALAN	9/10/98	00000000			
		CHECKER	R. ADRIANO	11/7/98				
		DES. ENCL.	A. LUDWIG	11/7/98				
		ITP						
		PREP. HSE						
		SCALE	1:1					
		DRAWING NUMBER	ECD-14654					B
		REV.	XY10A					
		TITLE	OUTLINE					
			F/163 YAG					

DANGER
 VISIBLE LASER RADIATION
 AVOID EXPOSURE TO DIRECT OR SCATTERED RADIATION

DANGER
 VISIBLE LASER RADIATION
 AVOID EXPOSURE TO DIRECT OR SCATTERED RADIATION

INDEX

	—C—		—P—
Customer Support, 3		Protection Glass Cleaning, 17	
	—F—		—S—
Federal Register, 10		Signals AChannel, 28 Definitions, 28	
	—G—	Specifications Environmental, 7 Mirrors, 7, 26 Scan Head, 25	
General Description, 6 Glossary, 23			—T—
	—I—		
Interconnections, 15		Troubleshooting, 21	
	—L—		—W—
Laser Classes, 10 Hazard Zones, 11 Shutter Installation, 11 Shutter Location, 11 Warning Label, 10		Warranty, 2	
Lens Cleaning, 17 Mounting, 13			—X—
	—M—	XY10A Lens Mounting, 13 Mirror Specifications, 26 Mounting, 14 Specifications, 25 XY10A Scan Head Definition, 5 Pin Configurations, 27	
Maintenance Lens Cleaning, 17 Mirror Cleaning, 18 Protection Glass Cleaning, 17 Scan Head Cleaning, 17			
Mirror Cleaning, 18			