

GSI Lumonics

HPM15M2 Hardware Manual

HPM15M2 Scan Head

**60 Fordham Road
Wilmington, MA 01887**

**GMAX™ SYSTEMS
MULTI-AXIS BEAM HANDLING**

TABLE OF CONTENTS

- 1. INTRODUCTION1
 - 1.1 Warranty..... 2
 - 1.2 Customer Support 3
 - 1.3 Unpacking 3
- 2. HPM15M2 OVERVIEW5
 - 2.1 Theory of Operation..... 5
 - 2.2 General Description 6
 - 2.3 Specifications 7
- 3. SAFETY AND WARNINGS9
 - 3.1 Laser Shutter Installation 11
 - 3.2 Installation Safety Requirements 12
- 4. INSTALLATION13
 - 4.1 Handling the HPM15M2 Scan Head Lens..... 13
 - 4.2 Mounting the HPM15M2 Scan Head..... 14
 - 4.3 HC/2 or HelperCard Installation 15
 - 4.4 Interconnections 16
- 5. MAINTENANCE17
 - 5.1 Lens / Protection Glass Cleaning 17
 - 5.1.1 Introduction..... 17
 - 5.1.2 Basic Cleaning Procedure 17
 - 5.1.2.1 Back-spatter / Burned-in Damage 18
 - 5.2 Mirror 18
 - 5.2.1 Cleaning Procedure 18
- 6. TROUBLESHOOTING21
- 7. GLOSSARY23
- 8. APPENDIX A: Specifications25
 - 8.1 HPM15M2 Scan Head 25
 - 8.2 HPM15M2 Scan Head Mirror..... 26
 - 8.3 HPM15M2 Scan Head Pin Configurations 27
- 9. APPENDIX B: Technical Outline Drawings29

High Performance Laser Scanning Module (HPM15M2) Hardware Manual

1. INTRODUCTION

This manual details the instructions on how to install and operate hardware of the High Performance Laser Scanning Module (**HPM15M2**). Included is information on setting up the hardware in preparation for your software commands, at which point you can refer to the proper software manual.

Be careful to observe the information in the Environmental Requirements section that alert you to the hazards and the laser beam path you can expect while running the **HPM15M2**.

Many of the details in this manual refer to the **XY15M2** Scan Head used within the **HPM15M2** module. This is because the **XY15M2** head is **extremely intricate**, and since it consists of the galvanometers that reflect the laser beam, it can be hazardous if certain precautions are not taken. Please be alert to the safety considerations and specific procedures regarding the **XY15M2** head and the laser you are using.

Conventions

Throughout the manual you will see graphic icons representing pertinent information in the text. The purpose of these icons is to provide a visual convention to alert you of a stop in the flow of the manual, where an important note or safety hazard alert is posted.





NOTE is an important procedure you should be aware of before proceeding.

CAUTION alerts you of a potential danger to equipment or the user.

WARNING indicates an imminent danger to the user.

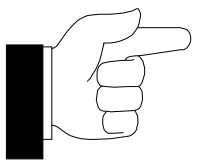
TIP and **REMINDER** are helpful hints to procedures listed in the text.

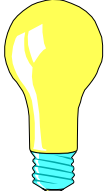
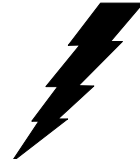
The conventions are listed as follows, showing both the text and the picture you will see.

NOTE	CAUTION	TIP	WARNING	REMINDER
				

GMAX, HC/2, HCI, PC-MARK MT, HPM and HPLK are trademarks of GSI Lumonics.
 Microsoft, MS-DOS and Windows are registered trademarks of Microsoft Corporation. HP is a registered trademark of Hewlett-Packard Company.

1.1 Warranty

GSI Lumonics (GSLI) warrants this product to be free from defects in materials and workmanship for 12 months from the date of shipment. GSLI will, at its option, repair or replace the product if it is defective within the warranty period and returned, freight pre-paid, to a service center designated by GSLI.

GSI Lumonics requests that customers obtain a Return Authorization Number prior to returning units, and that they carefully pack units in their original packing or equivalent.

Under warranty, GSLI is not obligated to repair damage to any units resulting from the following conditions (customers are responsible for defining which conditions are applicable to their product):

- a) Personnel other than GSLI representatives attempting to repair or service the product.
- b) Improper use of the equipment.
- c) Connecting the product to incompatible equipment.
- d) Personnel other than GSLI representatives modifying the product.
- e) Scratches and chips on any optical surface after three weeks from the date of receipt.
- f) Damage to any optical surface from improper handling or cleaning procedures. This applies specifically to those items subjected to excess laser radiation, contaminated environments, extreme temperature or abrasive cleaning.

Customers assume all responsibility for maintaining a laser-safe working environment. OEM customers must assume all responsibility for **CDRH** (Center for Devices and Radiological Health) certification.



NOTE

There is no implied warranty of fitness for a particular purpose, and GSLI is not responsible for consequential damages. Individual components manufactured by GSLI or others may be covered by their own warranties. Refer to the appropriate manuals for this information.

1.2 Customer Support

GSI Lumonics has support services available to you concerning problems with either the product or manual you are using.

Before calling for assistance, please make sure you refer to any appropriate sections in the manual that may answer your questions. The “Technical Outline Drawings” in APPENDIX B may be particularly helpful. If you need further assistance:

The customer service personnel will be able to give you direct assistance and answers to your questions.



U.S. (Massachusetts):	(978)-661-4300 (in the U. S.) +01 978-661-4300 (outside the U. S)
Germany (Munich):	+49 89 899134-0
Italy (Monza):	+39 39 2025387
UK (Banbury):	+44 132-787-2424
Japan (Tokyo):	+81 3 3406 7990

... ask for the GMAX Customer Service Department

1.3 Unpacking

A packing list is included in the shipment that details the exact items shipped.

- CAREFULLY unpack the contents from the box.
- Save shipping container and packaging material in case you need to return unit for service.
- Check contents of the box against the packing list to assure all parts have been received.
- Inspect each item to assure it is not damaged.

2. HPM15M2 OVERVIEW

2.1 Theory of Operation

The High Performance Laser Scanning Module (**HPM15M2**) is a multi-purpose-designed module. The module consists of 2 galvanometer scanners (X and Y), optics (flat field lens) and integrated driver electronics all enclosed in a black anodized aluminum case.

*X and Y Galvanometric
Scanners with a Flat
Field Lens*

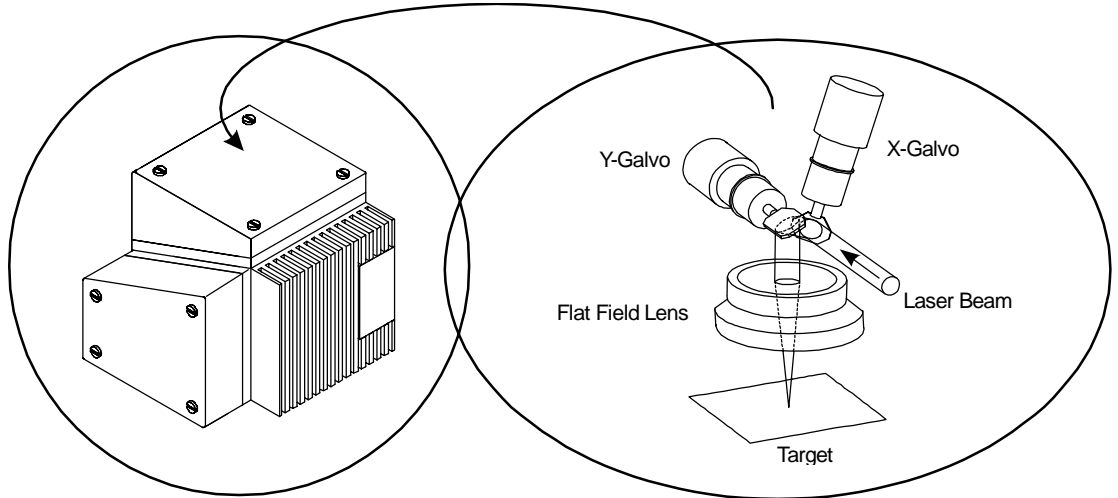

GSI Lumonics 2-mirror, 2-axis galvanometer Scan Heads provide the capability of deflecting optical beams in an XY manner for all possible laser applications. The synchronized actions of two galvanometer servo-controlled turning mirrors direct the laser beam to specific locations on a target material surface in both the X and Y directions.

PC-MARK MT (or **PC-MARK**) and **JOB EDITOR** (optional), sophisticated laser control software, controls the motion of the galvanometer according to the design selected by the user. The two circuit boards (galvanometer drivers) located in the Scan Head are connected to the computer controller through the **HC/2** or **HelperCard**. A 25-pin inter-connecting cable links the drivers to the **HC/2** or **HelperCard**.

2.2 General Description

The **HPM15M2** is a basic building block for the construction of a laser beam positioning system. It is intended for use by OEM customers, integrators, and sophisticated end-users. It consists of a purposely designed integrated deflection head with a PC based hardware and software package. The following block diagram shows the typical **HPM15M2** system components provided by GSI Lumonics.

*Block Diagram of a
Typical HPM15M2
System*

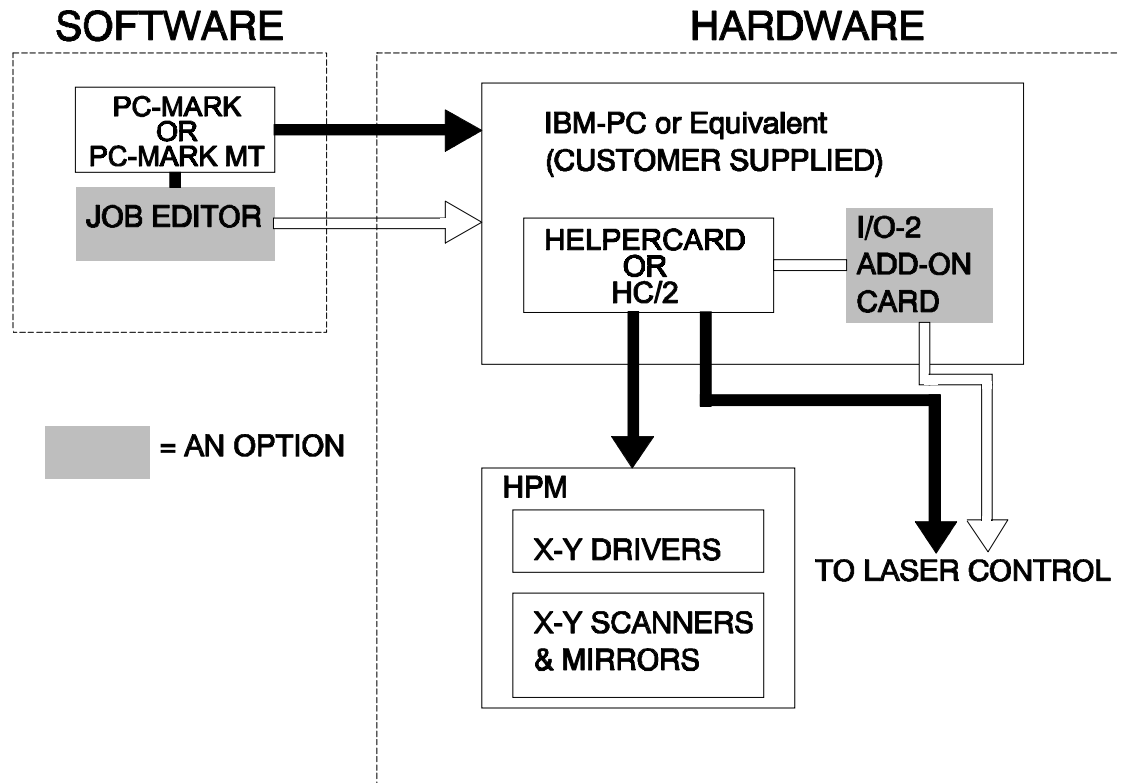

GSI Lumonics provides the following items that make up the full HPM15M2 package:

- **XY15M2** Scan Head with 2 galvanometer scanners, optics and integrated driver electronics.
- PC-installed **HC/2** or **HelperCard** (I/O-2 add-on control card optional).
- 10 ft. digital interface cable.
- Software package **PC-MARK MT** (multi-tasking) or **PC-MARK**, (**JOB EDITOR** optional).
- Documentation.

The Customer must provide:

- A laser.
- A computer (IBM PC compatible).
- A method of mounting the **HPM15M2**.
- Power Supply with the following specifications:

Power Supply Specifications

Voltage	±15 V +60%-20%
Current	2A
Ripple	≤ 0.2%
Noise	≤ 0.5% DC to 30MHz

Minimal Computer Requirements

The minimal configuration for the computer depends on your **HC/2** or **HelperCard**. For more information see the appropriate manuals.

2.3 Specifications

Environmental Requirements

Storage Temperature:	-10°C to +60°C
Minimum Operation Temperature:	+15°C
Maximum Operating Temperature:	+34°C
Humidity:	Non-condensing

XY15M2 Scan Head

Specifications and Pin Configurations are located in “APPENDIX A: Specifications”.

Mirrors

Specifications are located in “APPENDIX A: Specifications”.

3. SAFETY AND WARNINGS

The United States Food and Drug Administration, through the Center for Devices and Radiological Health (CDRH), has promulgated regulations (21 CFR parts 1000 and 1040) controlling the safety of lasers and laser products for sale or manufacture in the United States. GSI Lumonics **XY Scan Heads** are regulated by the CDRH.

This section is a guide to the specific areas of this product and to the manual(s). Pay particular attention to CDRH compliance information.

*User
Responsibilities*

GSI Lumonics **XY Scan Head** are designed to provide maximum flexibility and ease of use. Such a design inherently requires the user to assure the overall safety of the configuration in use.

It is the user's responsibility to insure that:

- 1) Only lasers certified to comply to CDRH regulations are used with GSI Lumonics **XY Scan Heads**.
- 2) Certified lasers contain features to assist in their safe usage. These protective features and the protective features within the GSI Lumonics **XY Scan Heads** should not be defeated.



CAUTION

Prior to operating any configuration of the GSI Lumonics XY Scan Heads, you must make a thorough analysis of system safety. Key information for this purpose is contained in this manual. You would thoroughly familiarize yourself with all this information before proceeding.

Laser Hazard Analysis

A full description of laser hazard analysis is beyond the scope of this manual. A good technical survey of laser safety requirements can be found in **ANSI Z136.1, "American National Standard For the Safe Use of Lasers"**. This is available from:

*American National Standards Institute, Inc.
1430 Broadway
New York, New York 10018*

Among the many other sources of laser safety information, the following institution offers several excellent publications.:

*The Laser Institute of America
5151 Monroe Street, Suite 118W
Toledo, Ohio 43623*

Final analysis of all safety features should be made by your Laser Safety Officer or a competent specialist in this field.

The first consideration in a safety analysis is the laser mated to the GSI Lumonics **XY Scan Head**. The hazard level of the laser is roughly indicated by the Laser Class label that is on the device. A brief description of the radiation classes are shown in the following table.

Note that, besides radiation, lasers may present other hazards, e.g.; electric shock or creation of poisonous fumes.

Classes and Characteristics of Lasers

LASER CLASS	DESCRIPTION
Class I	Lasers are not considered to be hazardous.
Class IIa	Lasers are hazardous if viewed for periods greater than one thousand seconds.
Class II	Lasers are chronic viewing hazards.
Class IIIa	Lasers may represent acute, intrabeam viewing or chronic or acute viewing hazards when viewed with optical instruments.
Class IIIb	Lasers are an acute hazard to skin and eyes from direct radiation.
Class IV	Lasers are an acute hazard to skin and eyes from direct or scattered radiation.



CAUTION

Do not use equipment outside of these ranges, as additional hazards may result.

Because we do not determine the laser used with our product, all GSI Lumonics end-user **XY Scan Heads** are labeled at the highest hazard level (Class IV). You should obtain information on output power or energy, wavelength(s) of output, duration of pulse, beam size and beam divergence from the manufacturer of the laser you are using.

The wavelength and power of the laser actually used should be written on the warning logo type label, Position 2. (See Section page 33699 and 33700 of the Federal Register, Appendix B). Be sure to use a permanent, indelible ink.

Class IV Warning Label

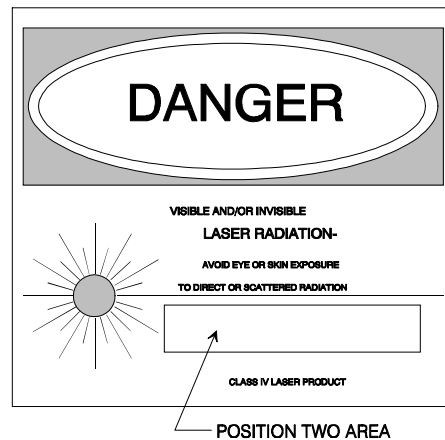

The Federal Register Rules and Regulations, Vol. 50, No. 161, dated Tuesday, August 20, 1985, contains the performance standards adopted by the Food and Drug Administration (FDA) which gives detailed information regarding the determination of laser classification and labeling. The ANSI and the FDA classifications are not the same. For purposes of labeling, use only the FDA classifications. If your laser falls in a classification below Class 4, replace the warning label type with the correct label and appropriate classification. The factory provides alternate labels upon request.



REMEMBER

The GSI Lumonics **XY Scan Heads** provide you with the ability to aim the laser beam over a roughly pyramidal volume. The divergence of the focused beam beyond the focal point, which is a function of the lenses selected and their position, can cause radiation to exit the pyramid. When analyzing safety, you must consider all regions within this aiming pyramid, the divergent beam, and the effects of all focal possibilities in the zone of hazard. Reflections must also be considered.

3.1 Laser Shutter Installation



The laser attenuator (shutter) is not included with the **XY Scan Head**. Because each laser is unique, it is the user's responsibility to insure that such a device is incorporated in the installation in conformance with CFR regulations (1040.10[f][6]), which reads as follows:

A beam attenuator is required on Class II, IIIa, IIIb and IV laser systems. The beam attenuator is a mechanical or electrical device such as a shutter or attenuator that blocks emission. The beam attenuator blocks bodily access to laser radiation above Class I limits without the need to turn off the laser. The beam attenuator must be available for use at all times during operation. Power switches and key controls do not satisfy the attenuator requirement.

Laser Shutter Location Example in a HPLK System

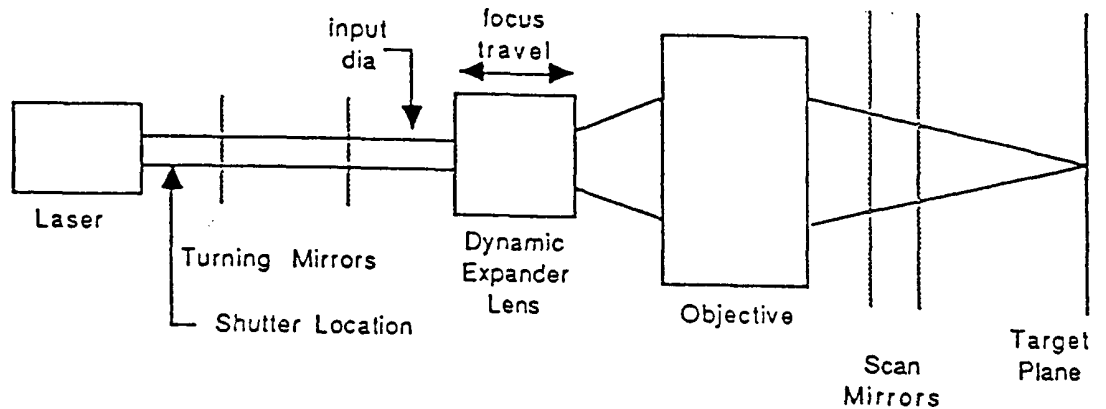

The beam shutter should be installed between the laser head and the Scan Head. The following figure shows the recommended location of the shutter.

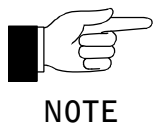

We strongly recommend that you specify a laser with a vendor-supplied shutter mechanism. If this is not possible, consult the laser vendor to design a proper safety shutter.

Laser Scanner Hazard Zones of an HPM Scan Head

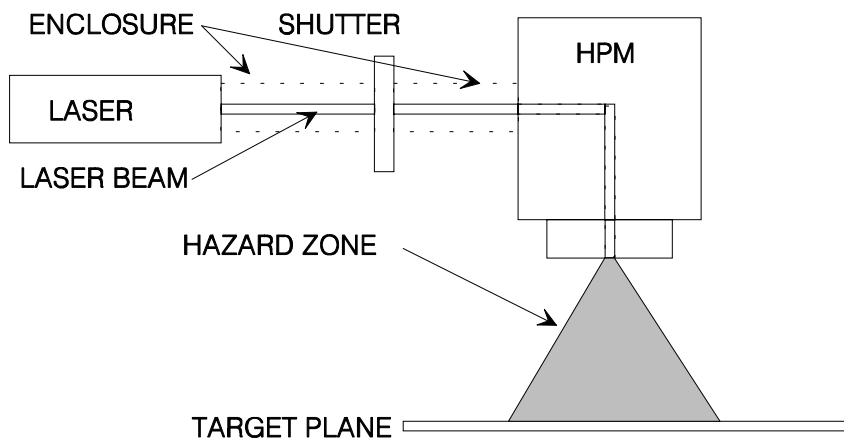

The figure shows the laser's internal and external optical path towards the target plane, specifically where the hazard zones are located as the optical beam passes through as **HPM Scan Head**.

3.2 Installation Safety Requirements

Because of the possible hazard increase of scanning stopping or slowing to an unsafe velocity, it is required that the controller software shuts down the laser power (a scanning safeguard).

In all cases, we recommend that you fully enclose and interlock the zone of hazard for your application to prevent possible opening while the laser is energized. When laser radiation exceeding Class 1 levels may exit the enclosure, you must have suitable protection for eyes available.



NOTE

At no time should you stare into the beam, place any parts of your body in the beam path, or expose yourself to reflections of powerful beams. You should use only a Class 1 HeNe Laser for alignment. If this is not possible, you should use the available laser's lowest power setting and remote beam sensing technique.



CAUTION

Using optical instruments with this product increases eye hazard.

Additional Safety requirements may be applicable during initial alignment of the optical system. Refer to Section, "Safety and Warnings", Section 3.

GSI Lumonics XY Scan Heads are labeled in conformance to the requirements of 21 CFR parts 1000 and 1040.

4. INSTALLATION

Installation Safety Requirements



WARNING

We recommend that you fully enclose and interlock the zone of hazard for your application to prevent possible opening while the laser is energized. If laser radiation exceeding Class 1 levels may exit the enclosure, you must have available suitable protection for your eyes.

At no time should you stare into the beam, place any parts of your body in the beam path, or expose yourself to reflections of powerful beams. You should use only a class I HeNe laser for alignment. If this is not possible, you should use the available laser's lowest power setting and remote beam sensing technique. Using optical instruments with this product increases eye hazard.

Additional Safety requirements may be applicable during initial alignment of the optical system. See the next section for specific safety information. GSI Lumonics **XY15M2** Scan Heads are labeled in conformance to the requirements of 21 CFR parts 1000 and 1040.

4.1 Handling the XY15M2 Scan Head Lens

If you have not purchased a lens with your **HPM15M2**, and you are installing your own lens, or you are removing a lens, follow the steps outlined below for handling and installing a lens.

*Lens Mounting
YAG Lens Example
(Complete Assembly)*

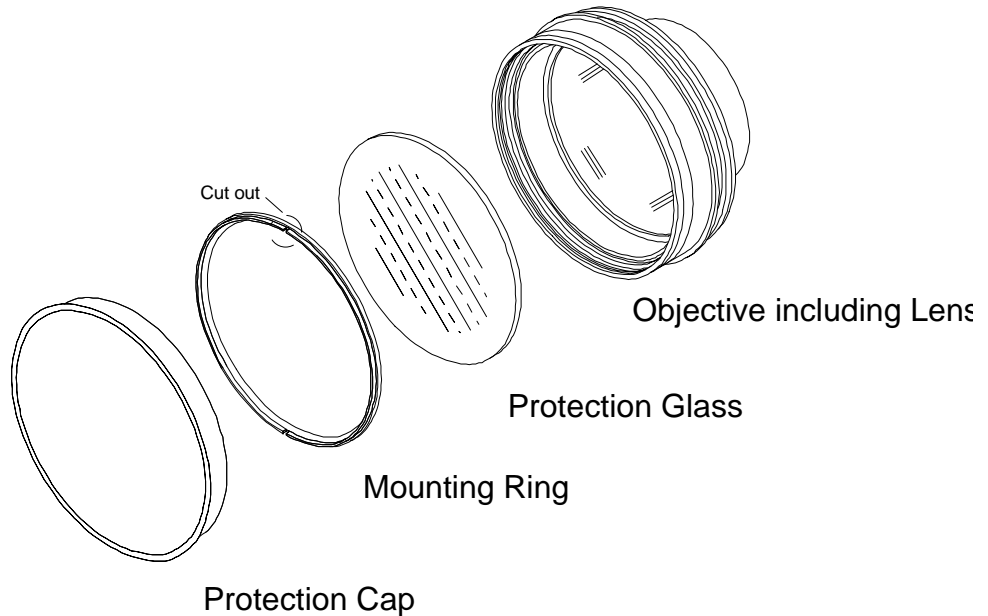

CAUTION

Make sure that the laser is off before performing any inspections! Wear finger cots or cotton gloves when handling optics for inspection.

To Install a Lens:

- 1) Before installing a lens onto the Scan Head, visually inspect the lens surface for any evidence of damage, i.e.; cracked lens, cracks on the edges of the lens, scratches on the lens surface.
- 2) If the lens is dirty, clean the lens per the lens cleaning instructions in the **MAINTENANCE**. Do not rest any objects on top of the lens as this may result in damaging the lens.
- 3) If there is a protection glass, make sure it is clean, then place it over the front of the lens. Screw the Mounting Ring into the lens flange until it is tight over the Protection Glass. Hand-fit lens protection cap onto the lens assembly.
- 4) The lens assembly is screwed into the Scan Head. Carefully and securely mount the lens to the **XY15M2** Scan Head. (DON'T CROSS-THREAD THE LENS ASSEMBLY). The lens should be screwed on completely.

To Remove a Lens:

Reverse the above procedure.

4.2 Mounting the HPM15M2 Scan Head

Scan Head Outline

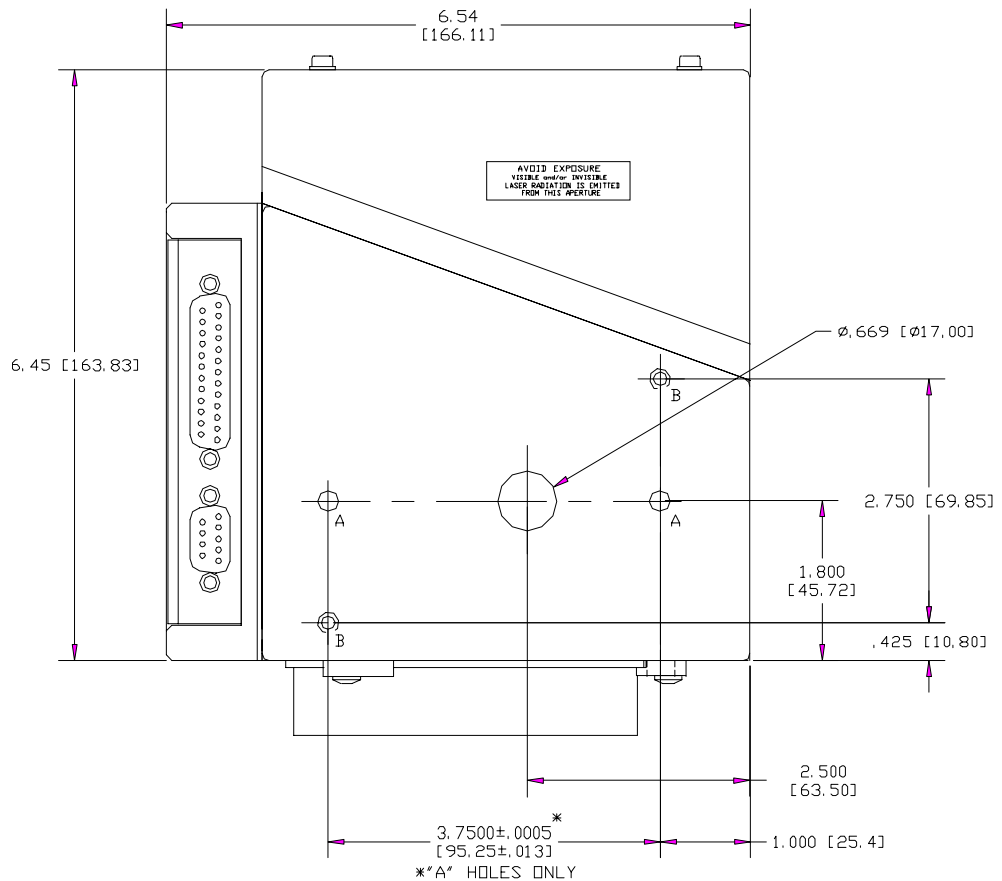

HOLE	QTY	SIZE / THREAD	DEPTH
B	4	M6	.24 [6.00]
A	2	∅.2367 ^{+0.0005} / _{-0.0000} [∅6mm F8]	.24 [6.00]

XY15M2 Mounting

- 1) The Scan Head requires a mounting flange that will match the mounting pins and holes on the **Beam Input** side of the assembly. The previous figure and the outline drawings, in Appendix C, can be used to determine the dimensions for manufacturing a mounting flange.
- 2) Line up the **HPM15M2** Scan Head module dowel holes with the dowel pins which protrude from your mounting flange.
- 3) Install the **HPM15M2** Scan Head module onto the pins.
- 4) Insert two M6 size buttonhead screws into the holes of the mounting flange. The screw length should be long enough to provide three or more full turns into the tapped holes.
- 5) Using an allen wrench, tighten the two screws. Alternate tightening the two screws so that the **HPM15M2** Scan Head comes together evenly with the mounting flange.

4.3 HC/2 or HelperCard Installation

The purpose of the **HC/2** or **HelperCard** is to provide a hardware link between the CPU and the **HPM15M2**. Both are cards designed to be installed into a PC type computer. For more information and installation procedure refer to the relevant manual.

4.4 Interconnections

The following figure depicts the connection of the **HPM15M2** Scan Head and the **HelperCard** to the various other Customer-supplied parts of the system.

HPM15M2 Connected to a System

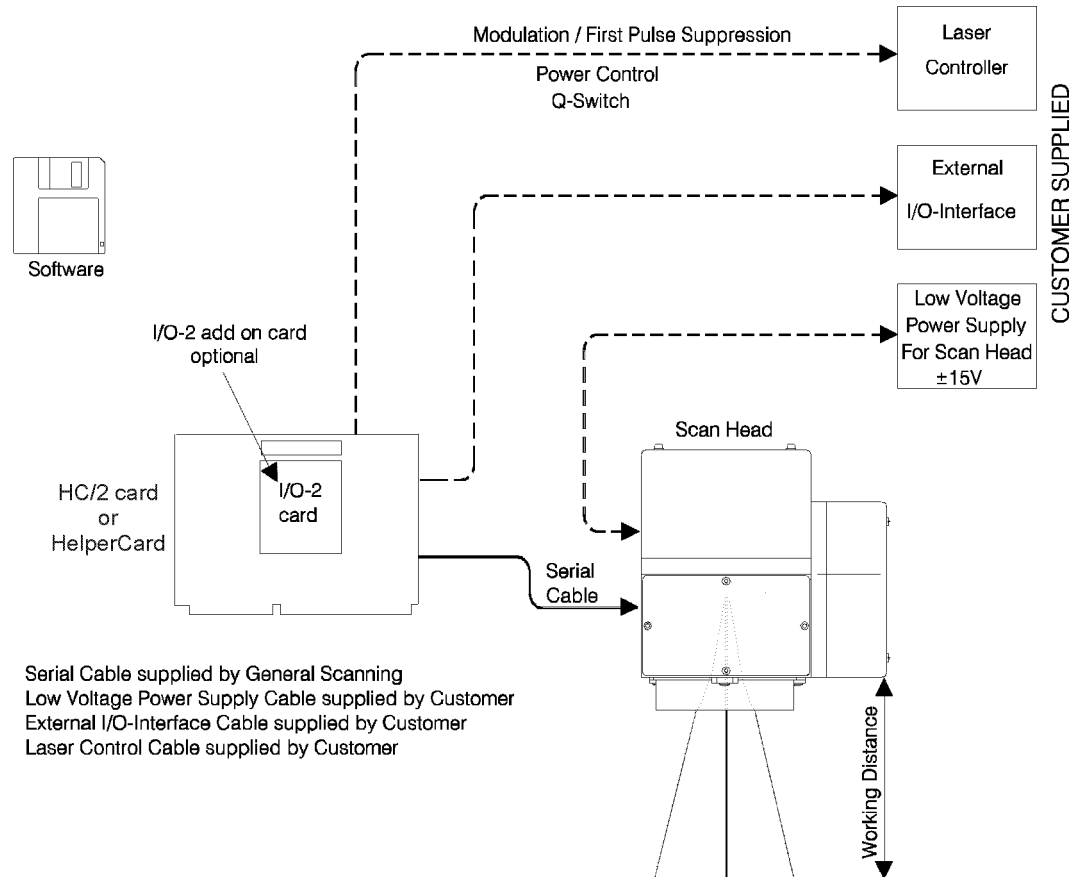

This completes the installation of the **HPM15M2** system. Install your software onto the computer. Refer to the software manuals for software installation.

5. MAINTENANCE

*Cleaning the
HPM15M2 Scan Head*

The HPM15M2 Scan Head assembly is sealed. The housing can be cleaned with a slightly dampened cloth. If a cleaning agent is necessary, use only a small quantity of non-aggressive cleanser (e.g. soap).

5.1 Lens / Protection Glass Cleaning

*Cleaning the Lens /
Protection Glass*

Special care should be exercised in cleaning a lens that does not have a protection window

5.1.1 Introduction

Optical materials and coatings are relatively soft materials and incorrect cleaning techniques can lead to surface damage and drastically reduced component lifetime.

Surface contamination can be of different kinds:

- Dust, grease and other air-borne particles.
- Products from the laser process - back spatter or burned-in particles.
- Organic contamination caused by talking, coughing or sneezing near the exposed optical surface.

The primary goal is to avoid any contamination by appropriate protection of the exposed optics!

The basic cleaning technique described here is intended to help prolong the component lifetime by minimizing surface damage during the cleaning process.



CAUTION

Not following this technique can cause severe damage to the optical components.

5.1.2 Basic Cleaning Procedure

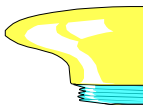

TIP

Optical components should always be handled using suitable gloves, or finger-cots, in order to avoid finger prints.

1. Surface dust and loose particles must be blown from the component using an air bulb, ideally one with a non-return valve.
2. Always use cloth or cotton buds which are moistened with **pure** acetone. Never use cleaning materials which are dry.
3. Use a soft, lint-free lens cloth. The cloth has to be moistened with pure acetone, laid gently on one edge of the component and drawn in a continuous movement to the opposite edge.

DO NOT APPLY PRESSURE. DO NOT RUB!



CAUTION

Rubbing may cause permanent surface marks.

4. Blow away residue liquid in one direction with an air bulb.
5. Make sure that no visual contaminants remain on the optical surface.
6. Stubborn stuck-on particles may require an attempt to dislodge them by the local application of a cotton bud moistened with pure acetone.
7. Finish off per (3) above.
8. Organic contamination cannot usually be removed using solvents such as acetone. The residue should be removed using distilled water and a lens cloth prior to finishing per (3) above.

5.1.2.1 Back-spatter / Burned-in Damage

Some forms of back-spatter can be reduced or removed using the basic cleaning process.

In general, however, metallic back-spatter or laser-burned-in damage cannot be removed by cleaning.

If the extent of the contamination is sufficient to cause process problems (e.g.: thermal lensing), then consideration should be given to replacement of the contaminated component.

5.2 Mirror



CAUTION

Never touch the coating of the mirror to avoid any damages on the surface.

There are times, however, when cleaning the mirror becomes a necessity. Follow exactly the next section "Cleaning Procedure".

5.2.1 Cleaning Procedure

Although the mirrors can be replaced by the user, we do **not recommend** you do so. Furthermore, **GSI Lumonics does not recommend cleaning front surface mirrors.** Mirrors damaged by cleaning are not included under the warranty. The surface of these mirrors damages easily. It is difficult to prevent hard dust particles from being entrained in the process and causing scratches. In many cases, small defects in the mirror's surface may be less harmful than the surface damage resulting from continued cleaning. It requires special equipment typically not available to customers.

There are times, however, when cleaning the mirror becomes a necessity, e.g. stains such as fingerprints must be removed immediately to prevent permanent etching of the reflective surface. The information below includes general recommendations for those special occasions when mirrors must be cleaned.

Removing Dust

Remove lint from mirrors with a jet of low pressure clean air. Blowing on front surface mirrors deposits moisture that may stain the finish.

Removing Stains

A thin overcoating of silicon monoxide protects most mirrors from oxidation. Like many optical coatings, it is easily damaged when attempts are made to clean the mirror surface with a dry tissue.

The safest method of cleaning is to place a piece of lens tissue on the mirror surface and wet it with reagent grade (highly pure) alcohol or acetone (If you use acetone, take precautions regarding possible health and fire hazards). Grasp an overhanging corner of the tissue and gently agitate it several times, then slide the tissue off. This should remove the problem blemishes.



CAUTION

Do not let solvent enter the bounding zone of the mirror.



NOTE

Note that the mirror is not rubbed.

If the mirror surface is still contaminated, use a highly pure solvent such as alcohol or acetone and generously wet the mirror surface with a **sterile** cotton swab or lens tissue. Gently wipe the dirty areas. Turn your cotton swab or tissue with each stroke so that a clean area is exposed.



CAUTION

Do not let solvent enter the scanner bearings. When wetting the mirror's surface, hold the scanner at an angle so that the liquid does not wet the scanner. If any solvent is found in the bearings of the scanner, the warranty is voided.

6. TROUBLESHOOTING

If you encounter problems with your **HPM15M2**, you can check the following matrix. If you cannot solve the problem, contact **GSI Lumonics** for further assistance.

PROBLEM	PROBABLE CAUSE	POSSIBLE SOLUTION
1. Decrease in marking quality.	1. Dirty protection glass.	1. Clean glass per instructions in Maintenance Section.
	2. Marking parameters changed.	1. Check PC-MARK MT (or PC-MARK) and JOB EDITOR parameters.
	3. Drop in output power.	1. Check laser power.
2. Laser will not mark when ordered by computer.	1. Laser modulation malfunction.	1. Check connections between HC/2 or HelperCard and laser controller. 2. Check connections between laser controller and laser.
	2. No power to galvanometers.	1. Check power connections to scanning head.
	3. HC/2 or HelperCard malfunction.	1. Verify that HC/2 or HelperCard connections and installation are correct.

7. GLOSSARY

- Flat Field Lens:* A wavelength specific lens focuses the laser to a small spot and maintains this spot size over the entire target field.
- Galvanometer:* A scanner with limited rotation magnetic torque motor with position feedback. The galvanometer (galvo) rotates a mirror to direct the laser beam.
- HC/2:* A PC based board that provides the hardware link between your PC and the XY Industrial Scan Head. I/O for laser control and parts handling are additional features. The HC/2 is fully compatible with PC-MARM MT (multitasking) software.
- HPGL:* HP® Graphics Language, a graphics format which PC-MARK MT can translate into vector data for scanning.
- HPM:* (High Performance Modules) Complete beam position packages consisting of the XY Industrial Scan Head, PC resident HC/2 card, PC-MARK MT software and interconnects.
- I/O-2:* An add-on board available as an option to the HC/2 card. Features include opto-isolated programmable I/O ports, analog laser power control and first pulse suppression.
- PC-MARK MT:* (multitasking) A powerful front-end macro command language. PC-MARK MT accepts application commands to place text and graphics in the marking field and translates them into the appropriate lists of vectors. Users may also write their own PC-MARK MT programs in any one of many popular software languages. MMCL is utilized as the link to the HC/2 card.
- JOB EDITOR:* A menu-driven application program of PC-MARK MT that provides an extensive graphics user interface and file management. It allows the user to manipulate HPGL based graphics with an accurate real preview of one's job.

8. APPENDIX A: Specifications

8.1 HPM15M2 Scan Head

Laser Type	YAG			CO ₂	
	1,064 nm	1,064 nm	1,064 nm	10,600 nm	10,600 nm
Objective (f in mm)	f = 100	f = 163	f = 254	f = 200	f = 200 HP
Standard Field Size (mm ²)	33 x 33	120 x 120	180 x 180	140 x 140	140 x 140
Maximum Practical Field Size (mm ²) ¹	73 x 73	120 x 120	185 x 185	140 x 140	140 x 140
Spot Size TEM ₀₀ (μm)	~16	~22	~33	~300	~200
Working Distance (mm) ²	117	210	348	180	204
Resolution (μm) ³	< 4	< 6	< 9.5	< 7.5	< 7.5
Writing Speed (m/s) ⁴	> 1.5	> 2.5	> 3.8	> 3.0	> 3.0
Uncalibrated Non-Linearity (maximum %) ⁵	±0.16	±0.16	±0.16	±0.56	±0.56
Temperature Drift (maximum μm/°C) ⁶	8.8	14.4	22.2	16.8	16.8
Aperture (mm)	15	15	15	15	15
Scan Angle (maximum)	±21°	±21°	±21°	±21°	±21°
Power Capability, cw (W/cm ²) ⁷	500	500	500	500	500
Power Capability, 100 ns pulsed (MW/cm ²)	100	100	100	400	400
Protection Glass	yes	yes	yes	none	none
Scan Head Size ⁸ (height x length x with in mm)	165x184x191	165x187x191	165x209x191	165x171x191	165x171x191
Weight (kg) ⁹	3.4	3.8	4.4	3.3	3.4
Surface Finish	black anodized	black anodized	black anodized	black anodized	black anodized
Protection	IP40+	IP40+	IP40+	IP40+	IP40+

¹ Some beam clipping can occur

² Distance between edge of head and working field

³ Better than 2 bit in a 16-bit system (±0.003 %)

⁴ Actual writing speed depends on accuracy and feature sizes (jump speeds can be much higher)

⁵ Includes lens distortion; non-linearity can be improved by an order of magnitude by using individual calibration methods in software

⁶ Temperature drift is maximum 0.012 %/°C and typ. 0.008 %/°C

⁷ Determined by the mirror specifications

⁸ Scan head basic dimensions without the lenses: Height = 165 mm, Length = 167 mm, Width = 191 mm

⁹ Scan Head weight without lens: 3.0 kg

Non-lens mirror configuration options: Argon, Argon (HP), UV and Visible

8.2 HPM15M2 Scan Head Mirror

	LASER TYPE					
	YAG	CO2	ARGON	ARGON (HP)	UV	VISIBLE
Wavelength	1,064 nm	10,600 nm	488-514 nm	488-514 nm	325-360 nm	450-700 nm
Coating	Dielectric	Dielectric on Metal	Dielectric	Dielectric	Dielectric	Durable Ag
Reflection (min.) @ Wavelength (nm)	99.5% @ 1,064 80.0% @ 450-650	99.5%	98.0% @ 480-514 50.0% @ 633	99.5%	98.0% @ 325-350 95.0% @ 350-360 45.0% @ 633	96.0%
Flatness @ 633 nm	$\lambda/4$	$\lambda/4$	$\lambda/4$	$\lambda/4$	$\lambda/4$	$\lambda/4$
Power Capability, cw (W/cm²)	500	500	100	5 MW/cm ²		10
Power Capability, 100 ns pulsed (MW/cm²)	100	400	80	2 GW/cm ² (10 ns pulsed)		N/A
Surface Quality (Scratch/Dig)	40/20	40/20	40/20	40/20	40/20	40/20

See your GSI Lumonics sales representative for more details.

8.3 HPM15M2 Scan Head Pin Configurations

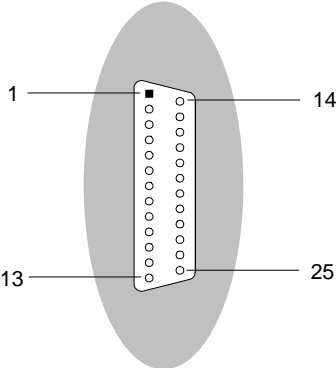
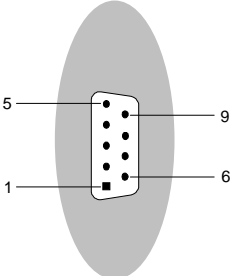
INTERFACE	PIN	ASSIGNMENT
 <p data-bbox="565 1024 938 1079">25 Pin D-Sub female connector for HC/2 or HelperCard</p>	<p data-bbox="1019 428 1045 449">1</p> <p data-bbox="1019 464 1045 485">14</p> <p data-bbox="1019 499 1045 520">2</p> <p data-bbox="1019 535 1045 556">15</p> <p data-bbox="1019 571 1045 592">3</p> <p data-bbox="1019 606 1045 627">16</p> <p data-bbox="1019 642 1045 663">4</p> <p data-bbox="1019 678 1045 699">17</p> <p data-bbox="1019 714 1045 735">5</p> <p data-bbox="1019 749 1045 770">18</p> <p data-bbox="1019 785 1045 806">6</p> <p data-bbox="1019 821 1045 842">19</p> <p data-bbox="1019 856 1045 877">7</p> <p data-bbox="1019 892 1045 913">20</p> <p data-bbox="1019 928 1045 949">8</p> <p data-bbox="1019 963 1045 984">21</p> <p data-bbox="1019 999 1045 1020">9</p> <p data-bbox="1019 1035 1045 1056">22</p> <p data-bbox="1019 1071 1045 1092">10</p> <p data-bbox="1019 1106 1045 1127">23</p> <p data-bbox="1019 1142 1045 1163">11</p> <p data-bbox="1019 1178 1045 1199">24</p> <p data-bbox="1019 1213 1045 1234">12</p> <p data-bbox="1019 1249 1045 1270">25</p> <p data-bbox="1019 1285 1045 1306">13</p>	<p data-bbox="1094 428 1208 449">SENDCK -</p> <p data-bbox="1094 464 1208 485">SENDCK +</p> <p data-bbox="1094 499 1175 520">SYNC -</p> <p data-bbox="1094 535 1175 556">SYNC +</p> <p data-bbox="1094 571 1240 592">CHANNEL X -</p> <p data-bbox="1094 606 1240 627">CHANNEL X +</p> <p data-bbox="1094 642 1240 663">CHANNEL Y -</p> <p data-bbox="1094 678 1240 699">CHANNEL Y +</p> <p data-bbox="1094 714 1370 735">RESERVED FOR Z AXIS</p> <p data-bbox="1094 749 1370 770">RESERVED FOR Z AXIS</p> <p data-bbox="1094 785 1208 806">STATUS -</p> <p data-bbox="1094 821 1208 842">STATUS +</p> <p data-bbox="1094 856 1127 877">NC</p> <p data-bbox="1094 892 1127 913">NC</p> <p data-bbox="1094 928 1127 949">NC</p> <p data-bbox="1094 963 1127 984">NC</p> <p data-bbox="1094 999 1143 1020">LM -</p> <p data-bbox="1094 1035 1143 1056">LM +</p> <p data-bbox="1094 1071 1127 1092">NC</p> <p data-bbox="1094 1106 1289 1127">SHIELD GROUND</p> <p data-bbox="1094 1142 1289 1163">SHIELD GROUND</p> <p data-bbox="1094 1178 1289 1199">SHIELD GROUND</p> <p data-bbox="1094 1213 1127 1234">NC</p> <p data-bbox="1094 1249 1256 1270">SHUTTER OUT</p> <p data-bbox="1094 1285 1240 1306">SHUTTER IN</p>
INTERFACE	PIN	ASSIGNMENT
 <p data-bbox="581 1640 922 1694">9 Pin D-Sub male connector for power supply</p>	<p data-bbox="1019 1388 1045 1409">5</p> <p data-bbox="1019 1423 1045 1444">9</p> <p data-bbox="1019 1459 1045 1480">4</p> <p data-bbox="1019 1495 1045 1516">8</p> <p data-bbox="1019 1530 1045 1551">3</p> <p data-bbox="1019 1566 1045 1587">7</p> <p data-bbox="1019 1602 1045 1623">2</p> <p data-bbox="1019 1638 1045 1659">6</p> <p data-bbox="1019 1673 1045 1694">1</p>	<p data-bbox="1094 1388 1159 1409">+VSS1</p> <p data-bbox="1094 1423 1159 1444">+VSS1</p> <p data-bbox="1094 1459 1159 1480">+VSS2</p> <p data-bbox="1094 1495 1143 1516">GND</p> <p data-bbox="1094 1530 1143 1551">GND</p> <p data-bbox="1094 1566 1143 1587">GND</p> <p data-bbox="1094 1602 1159 1623">-VSS2</p> <p data-bbox="1094 1638 1159 1659">-VSS1</p> <p data-bbox="1094 1673 1159 1694">-VSS1</p>

9. APPENDIX B: Technical Outline Drawings

This Appendix includes the following outline drawings:

DRAWING TITLE	DRAWING NUMBER
OUTLINE, HPM15M2 W/O MOUNTING RING OR LENS	ECD-17347
OUTLINE, HPM15M2 f/100 YAG	ECD-17491
OUTLINE, HPM15M2 f/163 YAG	ECD-16670
OUTLINE, HPM15M2 f/254 YAG	ECD-17511
OUTLINE, HPM15M2 f/200 CO ₂	ECD-17446
OUTLINE, HPM15M2 f/200 HP CO ₂	ECD-17498
OUTLINE, HPM15M2 300 YAG	ECD-20346

THIS DRAWING IS THE PROPERTY OF CAL LUMINONICS. IT IS TO BE USED ONLY FOR THE PROJECT AND QUANTITY SPECIFIED. IT IS NOT TO BE REPRODUCED, COPIED, OR TRANSMITTED IN ANY FORM OR BY ANY MEANS, ELECTRONIC OR MECHANICAL, INCLUDING PHOTOCOPYING, RECORDING, OR BY ANY INFORMATION STORAGE AND RETRIEVAL SYSTEM. CAL LUMINONICS ASSUMES NO LIABILITY FOR DAMAGES OF ANY KIND, INCLUDING CONSEQUENTIAL DAMAGES, ARISING FROM THE USE OF THIS DRAWING.

SYM	REVISION	RECORD	DATE	APP'D
1	RELEASED TO PE-PRODUCTION	EN-1000	11/27/95	GP.
A	REV PER EDCN-10067			GP.
B	REV PER EDCN-10373			GP.
C	REV PER EDCN-20049			GP.
D	REV PER EDCN-20152			GP.
E	REV PER EDCN-20144			GP.

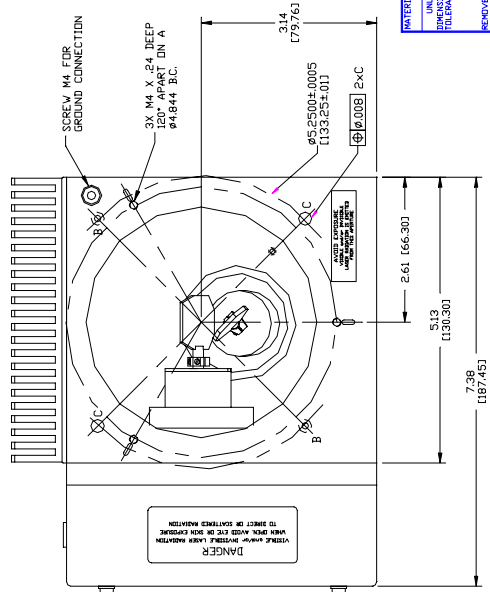
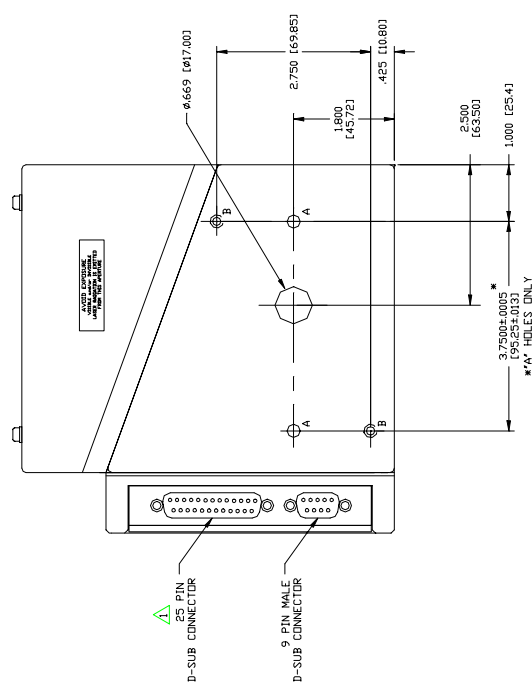
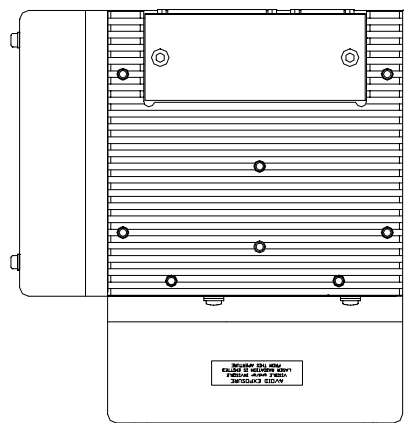
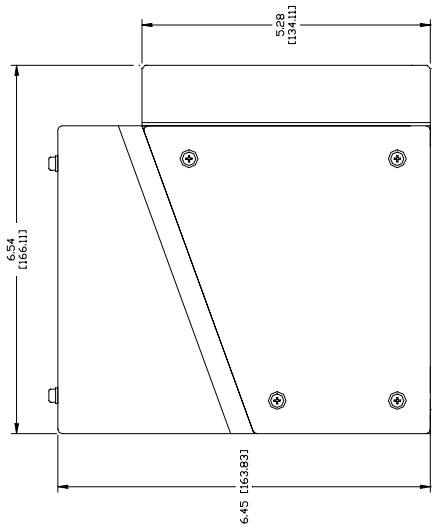

NOTES:
 A DIGITAL VERSION FEMALE,
 ANALOG VERSION MALE.

HOLE	QTY	SIZE / THREAD	DEPTH
C	2	Ø.2390 - .0002 L 6mm C11	.24 [6.00]
B	4	M6	.24 [6.00]
A	2	Ø.2367 - .0002 I 6mm F B1	.24 [6.00]

MATERIAL		TREATMENT		CAD FILE No.		FSD No.	
UNLESS SPECIFIED	FUNCTION	NAME	DATE	DATE	DATE	DATE	DATE
TELEPRINTERS	DRIVER	X. GEEK	4/27/95	4/27/95	4/27/95	4/27/95	4/27/95
XXXX = 2.000	RECOR	R. ADRIANO	12/19/95				
SHARP EDGE	DRS. ENG.	V. BAKER	12/27/95				
	DRS. ENG.	G. PALAUCCI	4/12/95				
	PROJ. MGR.						
	PROJ. MGR.						

OUTLINE, HPM15W2
 W/O MOUNTING RING OR LENS
 cal LUMINONICS
 3000 WILSON AVENUE
 WILSON, N.J.

DRAWING NUMBER: 3CD-17347
 REV: E

PROPERTY OF C&I LUMINOTES
 THIS DRAWING IS THE PROPERTY OF C&I LUMINOTES. IT IS TO BE USED ONLY FOR THE PROJECT AND QUANTITY SPECIFIED THEREIN. IT IS NOT TO BE REPRODUCED, COPIED, OR TRANSMITTED IN ANY FORM OR BY ANY MEANS, ELECTRONIC OR MECHANICAL, INCLUDING PHOTOCOPYING, RECORDING, OR BY ANY INFORMATION STORAGE AND RETRIEVAL SYSTEM. ANY UNAUTHORIZED USE OF THIS DRAWING IS STRICTLY PROHIBITED. C&I LUMINOTES ASSUMES NO LIABILITY FOR ANY DAMAGE OR LOSS OF PROFITS, BUSINESS, OR REVENUE, OR FOR ANY SPECIAL, CONSEQUENTIAL, OR INCIDENTAL DAMAGES, WHETHER IN AN ACTION OF CONTRACT, TORT, OR OTHERWISE, ARISING FROM THE USE OF THIS DRAWING.

SYM	REVISION	RECORD	DATE	APPROVA
A	RELEASED TO PRODUCTION ECH-18006			
B	REV PER ECH-18372		3/29/96	G.P.
C	REV PER ECH-21049		4/27/97	G.P.
D	REV PER ECH-51372		5/1/98	G.P.
E	REV PER ECH-8514			

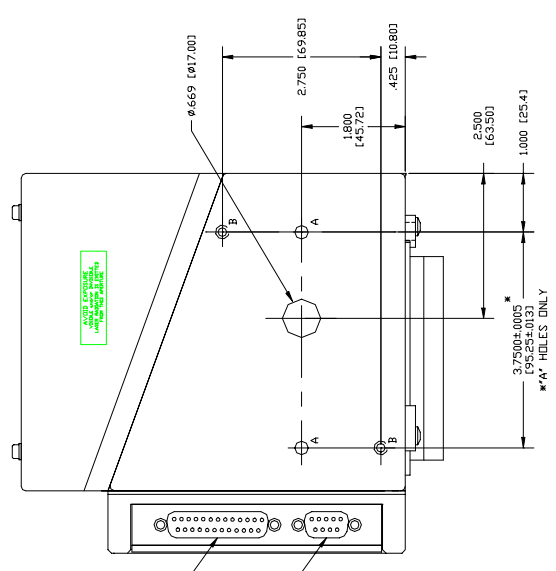
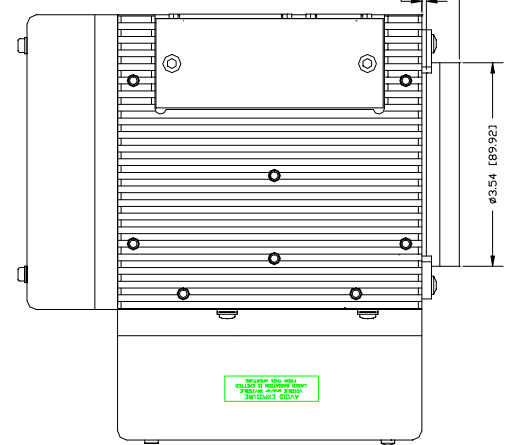
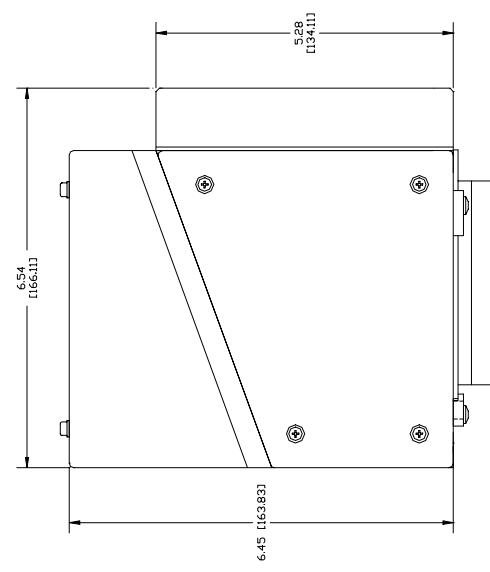

AVOID EXPOSURE TO LASER RADIATION

25 PIN CONNECTOR
 9 PIN MALE D-SUB CONNECTOR

AVOID EXPOSURE TO LASER RADIATION

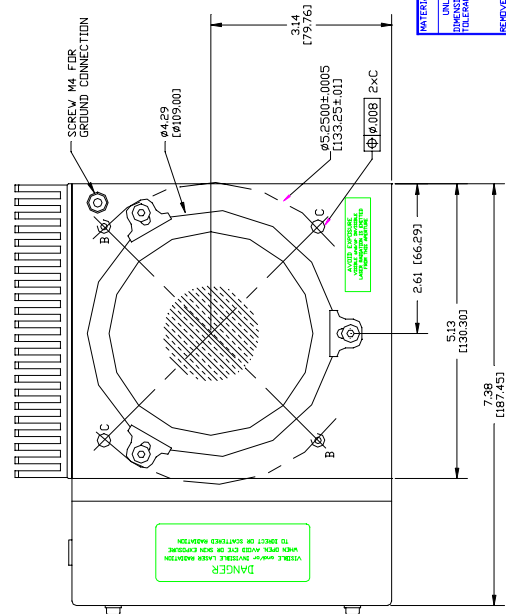

AVOID EXPOSURE TO LASER RADIATION

NOTES:
 ▲ DIGITAL VERSION FEMALE, ANALOG VERSION MALE.

HOLE	QTY	SIZE / THREAD	DEPTH
C	2	Ø.2390 * .0028 [6mm C11]	.24 [6.00]
B	4	M6	.24 [6.00]
A	2	Ø.2367 * .0028 [Ø6mm F8]	.24 [6.00]

FUNCTION	NAME	DATE	ESCH. NO.
DRAWN	B.P. STONE	1/12/96	
CHECKER			
DES. ENG.	A. LUNEN	1/21/96	
MFG. ENG.	G. PAULUCCI	1/26/96	
PROJ. MGR.			

UNLESS SPECIFIED	UNLESS SPECIFIED
DIMENSIONS ARE IN INCHES	TOLERANCES ARE IN INCHES
XXX ± .005	XXX ± .005
XXX ± .010	XXX ± .010
XXX ± .020	XXX ± .020
XXX ± .050	XXX ± .050
XXX ± .100	XXX ± .100
XXX ± .150	XXX ± .150
XXX ± .200	XXX ± .200
XXX ± .300	XXX ± .300
XXX ± .500	XXX ± .500
XXX ± 1.000	XXX ± 1.000
XXX ± 1.500	XXX ± 1.500
XXX ± 2.000	XXX ± 2.000
XXX ± 3.000	XXX ± 3.000
XXX ± 4.000	XXX ± 4.000
XXX ± 5.000	XXX ± 5.000
XXX ± 6.000	XXX ± 6.000
XXX ± 8.000	XXX ± 8.000
XXX ± 10.000	XXX ± 10.000
XXX ± 15.000	XXX ± 15.000
XXX ± 20.000	XXX ± 20.000
XXX ± 30.000	XXX ± 30.000
XXX ± 40.000	XXX ± 40.000
XXX ± 50.000	XXX ± 50.000
XXX ± 75.000	XXX ± 75.000
XXX ± 100.000	XXX ± 100.000
XXX ± 150.000	XXX ± 150.000
XXX ± 200.000	XXX ± 200.000
XXX ± 300.000	XXX ± 300.000
XXX ± 400.000	XXX ± 400.000
XXX ± 500.000	XXX ± 500.000
XXX ± 750.000	XXX ± 750.000
XXX ± 1000.000	XXX ± 1000.000
XXX ± 1500.000	XXX ± 1500.000
XXX ± 2000.000	XXX ± 2000.000
XXX ± 3000.000	XXX ± 3000.000
XXX ± 4000.000	XXX ± 4000.000
XXX ± 5000.000	XXX ± 5000.000
XXX ± 7500.000	XXX ± 7500.000
XXX ± 10000.000	XXX ± 10000.000
XXX ± 15000.000	XXX ± 15000.000
XXX ± 20000.000	XXX ± 20000.000
XXX ± 30000.000	XXX ± 30000.000
XXX ± 40000.000	XXX ± 40000.000
XXX ± 50000.000	XXX ± 50000.000
XXX ± 75000.000	XXX ± 75000.000
XXX ± 100000.000	XXX ± 100000.000
XXX ± 150000.000	XXX ± 150000.000
XXX ± 200000.000	XXX ± 200000.000
XXX ± 300000.000	XXX ± 300000.000
XXX ± 400000.000	XXX ± 400000.000
XXX ± 500000.000	XXX ± 500000.000
XXX ± 750000.000	XXX ± 750000.000
XXX ± 1000000.000	XXX ± 1000000.000
XXX ± 1500000.000	XXX ± 1500000.000
XXX ± 2000000.000	XXX ± 2000000.000
XXX ± 3000000.000	XXX ± 3000000.000
XXX ± 4000000.000	XXX ± 4000000.000
XXX ± 5000000.000	XXX ± 5000000.000
XXX ± 7500000.000	XXX ± 7500000.000
XXX ± 10000000.000	XXX ± 10000000.000
XXX ± 15000000.000	XXX ± 15000000.000
XXX ± 20000000.000	XXX ± 20000000.000
XXX ± 30000000.000	XXX ± 30000000.000
XXX ± 40000000.000	XXX ± 40000000.000
XXX ± 50000000.000	XXX ± 50000000.000
XXX ± 75000000.000	XXX ± 75000000.000
XXX ± 100000000.000	XXX ± 100000000.000
XXX ± 150000000.000	XXX ± 150000000.000
XXX ± 200000000.000	XXX ± 200000000.000
XXX ± 300000000.000	XXX ± 300000000.000
XXX ± 400000000.000	XXX ± 400000000.000
XXX ± 500000000.000	XXX ± 500000000.000
XXX ± 750000000.000	XXX ± 750000000.000
XXX ± 1000000000.000	XXX ± 1000000000.000
XXX ± 1500000000.000	XXX ± 1500000000.000
XXX ± 2000000000.000	XXX ± 2000000000.000
XXX ± 3000000000.000	XXX ± 3000000000.000
XXX ± 4000000000.000	XXX ± 4000000000.000
XXX ± 5000000000.000	XXX ± 5000000000.000
XXX ± 7500000000.000	XXX ± 7500000000.000
XXX ± 10000000000.000	XXX ± 10000000000.000
XXX ± 15000000000.000	XXX ± 15000000000.000
XXX ± 20000000000.000	XXX ± 20000000000.000
XXX ± 30000000000.000	XXX ± 30000000000.000
XXX ± 40000000000.000	XXX ± 40000000000.000
XXX ± 50000000000.000	XXX ± 50000000000.000
XXX ± 75000000000.000	XXX ± 75000000000.000
XXX ± 100000000000.000	XXX ± 100000000000.000
XXX ± 150000000000.000	XXX ± 150000000000.000
XXX ± 200000000000.000	XXX ± 200000000000.000
XXX ± 300000000000.000	XXX ± 300000000000.000
XXX ± 400000000000.000	XXX ± 400000000000.000
XXX ± 500000000000.000	XXX ± 500000000000.000
XXX ± 750000000000.000	XXX ± 750000000000.000
XXX ± 1000000000000.000	XXX ± 1000000000000.000
XXX ± 1500000000000.000	XXX ± 1500000000000.000
XXX ± 2000000000000.000	XXX ± 2000000000000.000
XXX ± 3000000000000.000	XXX ± 3000000000000.000
XXX ± 4000000000000.000	XXX ± 4000000000000.000
XXX ± 5000000000000.000	XXX ± 5000000000000.000
XXX ± 7500000000000.000	XXX ± 7500000000000.000
XXX ± 10000000000000.000	XXX ± 10000000000000.000
XXX ± 15000000000000.000	XXX ± 15000000000000.000
XXX ± 20000000000000.000	XXX ± 20000000000000.000
XXX ± 30000000000000.000	XXX ± 30000000000000.000
XXX ± 40000000000000.000	XXX ± 40000000000000.000
XXX ± 50000000000000.000	XXX ± 50000000000000.000
XXX ± 75000000000000.000	XXX ± 75000000000000.000
XXX ± 100000000000000.000	XXX ± 100000000000000.000
XXX ± 150000000000000.000	XXX ± 150000000000000.000
XXX ± 200000000000000.000	XXX ± 200000000000000.000
XXX ± 300000000000000.000	XXX ± 300000000000000.000
XXX ± 400000000000000.000	XXX ± 400000000000000.000
XXX ± 500000000000000.000	XXX ± 500000000000000.000
XXX ± 750000000000000.000	XXX ± 750000000000000.000
XXX ± 1000000000000000.000	XXX ± 1000000000000000.000
XXX ± 1500000000000000.000	XXX ± 1500000000000000.000
XXX ± 2000000000000000.000	XXX ± 2000000000000000.000
XXX ± 3000000000000000.000	XXX ± 3000000000000000.000
XXX ± 4000000000000000.000	XXX ± 4000000000000000.000
XXX ± 5000000000000000.000	XXX ± 5000000000000000.000
XXX ± 7500000000000000.000	XXX ± 7500000000000000.000
XXX ± 10000000000000000.000	XXX ± 10000000000000000.000
XXX ± 15000000000000000.000	XXX ± 15000000000000000.000
XXX ± 20000000000000000.000	XXX ± 20000000000000000.000
XXX ± 30000000000000000.000	XXX ± 30000000000000000.000
XXX ± 40000000000000000.000	XXX ± 40000000000000000.000
XXX ± 50000000000000000.000	XXX ± 50000000000000000.000
XXX ± 75000000000000000.000	XXX ± 75000000000000000.000
XXX ± 100000000000000000.000	XXX ± 100000000000000000.000
XXX ± 150000000000000000.000	XXX ± 150000000000000000.000
XXX ± 200000000000000000.000	XXX ± 200000000000000000.000
XXX ± 300000000000000000.000	XXX ± 300000000000000000.000
XXX ± 400000000000000000.000	XXX ± 400000000000000000.000
XXX ± 500000000000000000.000	XXX ± 500000000000000000.000
XXX ± 750000000000000000.000	XXX ± 750000000000000000.000
XXX ± 1000000000000000000.000	XXX ± 1000000000000000000.000
XXX ± 1500000000000000000.000	XXX ± 1500000000000000000.000
XXX ± 2000000000000000000.000	XXX ± 2000000000000000000.000
XXX ± 3000000000000000000.000	XXX ± 3000000000000000000.000
XXX ± 4000000000000000000.000	XXX ± 4000000000000000000.000
XXX ± 5000000000000000000.000	XXX ± 5000000000000000000.000
XXX ± 7500000000000000000.000	XXX ± 7500000000000000000.000
XXX ± 10000000000000000000.000	XXX ± 10000000000000000000.000
XXX ± 15000000000000000000.000	XXX ± 15000000000000000000.000
XXX ± 20000000000000000000.000	XXX ± 20000000000000000000.000
XXX ± 30000000000000000000.000	XXX ± 30000000000000000000.000
XXX ± 40000000000000000000.000	XXX ± 40000000000000000000.000
XXX ± 50000000000000000000.000	XXX ± 50000000000000000000.000
XXX ± 75000000000000000000.000	XXX ± 75000000000000000000.000
XXX ± 100000000000000000000.000	XXX ± 100000000000000000000.000
XXX ± 150000000000000000000.000	XXX ± 150000000000000000000.000
XXX ± 200000000000000000000.000	XXX ± 200000000000000000000.000
XXX ± 300000000000000000000.000	XXX ± 300000000000000000000.000
XXX ± 400000000000000000000.000	XXX ± 400000000000000000000.000
XXX ± 500000000000000000000.000	XXX ± 500000000000000000000.000
XXX ± 750000000000000000000.000	XXX ± 750000000000000000000.000
XXX ± 1000000000000000000000.000	XXX ± 1000000000000000000000.000
XXX ± 1500000000000000000000.000	XXX ± 1500000000000000000000.000
XXX ± 2000000000000000000000.000	XXX ± 2000000000000000000000.000
XXX ± 3000000000000000000000.000	XXX ± 3000000000000000000000.000
XXX ± 4000000000000000000000.000	XXX ± 4000000000000000000000.000
XXX ± 5000000000000000000000.000	XXX ± 5000000000000000000000.000
XXX ± 7500000000000000000000.000	XXX ± 7500000000000000000000.000
XXX ± 10000000000000000000000.000	XXX ± 10000000000000000000000.000
XXX ± 15000000000000000000000.000	XXX ± 15000000000000000000000.000
XXX ± 20000000000000000000000.000	XXX ± 20000000000000000000000.000
XXX ± 30000000000000000000000.000	XXX ± 30000000000000000000000.000
XXX ± 40000000000000000000000.000	XXX ± 40000000000000000000000.000
XXX ± 50000000000000000000000.000	XXX ± 50000000000000000000000.000
XXX ± 75000000000000000000000.000	XXX ± 75000000000000000000000.000
XXX ± 100000000000000000000000.000	XXX ± 100000000000000000000000.000
XXX ± 150000000000000000000000.000	XXX ± 150000000000000000000000.000
XXX ± 200000000000000000000000.000	XXX ± 200000000000000000000000.000
XXX ± 300000000000000000000000.000	XXX ± 300000000000000000000000.000
XXX ± 400000000000000000000000.000	XXX ± 400000000000000000000000.000
XXX ± 500000000000000000000000.000	XXX ± 500000000000000000000000.000
XXX ± 750000000000000000000000.000	XXX ± 750000000000000000000000.000
XXX ± 1000000000000000000000000.000	XXX ± 1000000000000000000000000.000
XXX ± 1500000000000000000000000.000	XXX ± 1500000000000000000000000.000
XXX ± 2000000000000000000000000.000	XXX ± 2000000000000000000000000.000
XXX ± 3000000000000000000000000.000	XXX ± 3000000000000000000000000.000
XXX ± 4000000000000000000000000.000	XXX ± 4000000000000000000000000.000
XXX ± 5000000000000000000000000.000	

PROPERTY OF OSI LUMONICS
 THIS DRAWING IS THE PROPERTY OF OSI LUMONICS. IT IS TO BE USED FOR THE PROJECT AND QUANTITY SPECIFIED ONLY. IT IS NOT TO BE REPRODUCED, COPIED, OR TRANSMITTED IN ANY FORM OR BY ANY MEANS, ELECTRONIC OR MECHANICAL, INCLUDING PHOTOCOPYING, RECORDING, OR BY ANY INFORMATION STORAGE AND RETRIEVAL SYSTEM. ANY UNAUTHORIZED USE OF THIS DRAWING IS STRICTLY PROHIBITED. ALL RIGHTS ARE RESERVED.

SY#	REVISION	RECORD	DATE	APPROVE
1	RELEASED TO RE-PRODUCTION ECU-10027			
A	RELEASED TO PROD ECU-10373		3/5/96	GP.
B	REV PER ECU-10669		8/22/96	GP.
C	REV PER ECU-21049		4/3/97	GP.
D	REV PER ECU-25172		11/11/97	GP.
E	REV PER ECU-26174		3/7/98	GP.

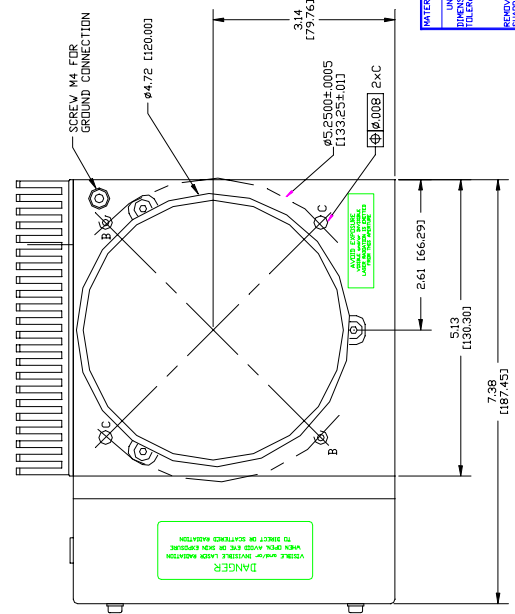
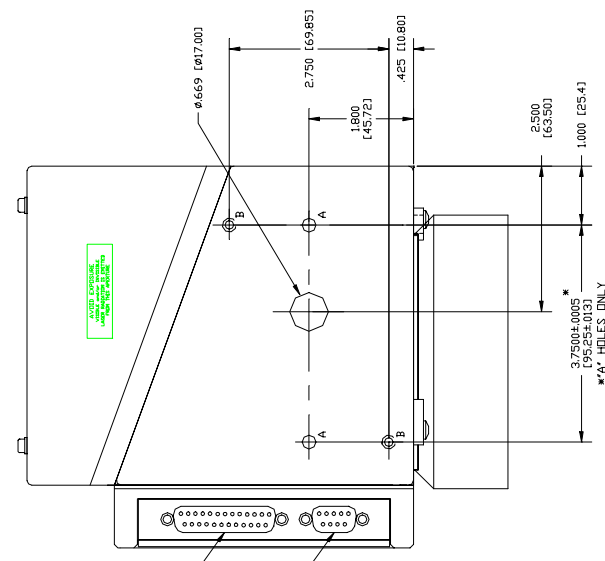
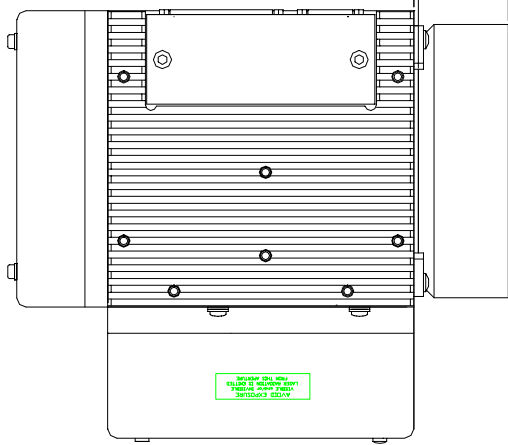
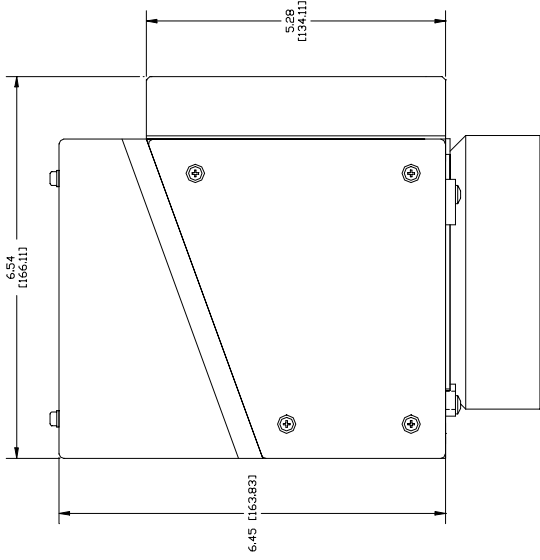

HOLE	QTY	SIZE / THREAD	DEPTH
C	2	Ø.2390 *5/64 C11	.24 [6.00]
B	4	M6	.24 [6.00]
A	2	Ø.2367 *5/64 F8	.24 [6.00]

NOTES:
 ▲ DIGITAL VERSION FEMALE,
 ▲ ANALOG VERSION MALE.

UNLESS SPECIFIED OTHERWISE, ALL DIMENSIONS ARE IN INCHES AND DECIMALS THEREOF.

UNLESS SPECIFIED OTHERWISE, ALL DIMENSIONS ARE IN INCHES AND DECIMALS THEREOF.

UNLESS SPECIFIED OTHERWISE, ALL DIMENSIONS ARE IN INCHES AND DECIMALS THEREOF.

MATERIAL		TREATMENT	
UNLESS SPECIFIED OTHERWISE, ALL DIMENSIONS ARE IN INCHES AND DECIMALS THEREOF.	FUNCTION	DATE	DATE
XXX ± .005	DRAWN	BP. STONE	1/22/96
XXX ± .010	CHECKER	R. ANGLAND	9/7/96
XXX ± .020	DIA.	DES. ENG.	A. LUDEN
XXX ± .030	AND	INS. ENG.	G. PALLOCI
XXX ± .040	PROB. WORK	PROB. WORK	1/26/96
XXX ± .050	IN	IN	
XXX ± .060	SCALE	SCALE	
XXX ± .070	1:1	1:1	
XXX ± .080	1:2	1:2	
XXX ± .090	1:4	1:4	
XXX ± .100	1:8	1:8	
XXX ± .125	1:16	1:16	
XXX ± .150	1:32	1:32	
XXX ± .180	1:64	1:64	
XXX ± .200	1:128	1:128	
XXX ± .250	1:256	1:256	
XXX ± .300	1:512	1:512	
XXX ± .375	1:1024	1:1024	
XXX ± .450	1:2048	1:2048	
XXX ± .500	1:4096	1:4096	
XXX ± .600	1:8192	1:8192	
XXX ± .750	1:16384	1:16384	
XXX ± .900	1:32768	1:32768	
XXX ± 1.000	1:65536	1:65536	
XXX ± 1.250	1:131072	1:131072	
XXX ± 1.500	1:262144	1:262144	
XXX ± 1.750	1:524288	1:524288	
XXX ± 2.000	1:1048576	1:1048576	
XXX ± 2.500	1:2097152	1:2097152	
XXX ± 3.000	1:4194304	1:4194304	
XXX ± 3.750	1:8388608	1:8388608	
XXX ± 4.500	1:67108864	1:67108864	
XXX ± 5.000	1:33554432	1:33554432	
XXX ± 6.000	1:16777216	1:16777216	
XXX ± 7.500	1:8388608	1:8388608	
XXX ± 9.000	1:4194304	1:4194304	
XXX ± 10.000	1:2097152	1:2097152	
XXX ± 12.500	1:1048576	1:1048576	
XXX ± 15.000	1:524288	1:524288	
XXX ± 18.000	1:262144	1:262144	
XXX ± 20.000	1:131072	1:131072	
XXX ± 25.000	1:52428.8	1:52428.8	
XXX ± 30.000	1:26214.4	1:26214.4	
XXX ± 37.500	1:13107.2	1:13107.2	
XXX ± 45.000	1:6553.6	1:6553.6	
XXX ± 50.000	1:3276.8	1:3276.8	
XXX ± 60.000	1:1638.4	1:1638.4	
XXX ± 75.000	1:819.2	1:819.2	
XXX ± 90.000	1:409.6	1:409.6	
XXX ± 100.000	1:204.8	1:204.8	
XXX ± 125.000	1:102.4	1:102.4	
XXX ± 150.000	1:51.2	1:51.2	
XXX ± 180.000	1:25.6	1:25.6	
XXX ± 200.000	1:12.8	1:12.8	
XXX ± 250.000	1:6.4	1:6.4	
XXX ± 300.000	1:3.2	1:3.2	
XXX ± 375.000	1:1.6	1:1.6	
XXX ± 450.000	1:0.8	1:0.8	
XXX ± 500.000	1:0.4	1:0.4	
XXX ± 600.000	1:0.2	1:0.2	
XXX ± 750.000	1:0.1	1:0.1	
XXX ± 900.000	1:0.05	1:0.05	
XXX ± 1000.000	1:0.02	1:0.02	
XXX ± 1250.000	1:0.01	1:0.01	
XXX ± 1500.000	1:0.005	1:0.005	
XXX ± 1800.000	1:0.002	1:0.002	
XXX ± 2000.000	1:0.001	1:0.001	
XXX ± 2500.000	1:0.0005	1:0.0005	
XXX ± 3000.000	1:0.0002	1:0.0002	
XXX ± 3750.000	1:0.0001	1:0.0001	
XXX ± 4500.000	1:0.00005	1:0.00005	
XXX ± 5000.000	1:0.00002	1:0.00002	
XXX ± 6000.000	1:0.00001	1:0.00001	
XXX ± 7500.000	1:0.000005	1:0.000005	
XXX ± 9000.000	1:0.000002	1:0.000002	
XXX ± 10000.000	1:0.000001	1:0.000001	
XXX ± 12500.000	1:0.0000005	1:0.0000005	
XXX ± 15000.000	1:0.0000002	1:0.0000002	
XXX ± 18000.000	1:0.0000001	1:0.0000001	
XXX ± 20000.000	1:0.00000005	1:0.00000005	
XXX ± 25000.000	1:0.00000002	1:0.00000002	
XXX ± 30000.000	1:0.00000001	1:0.00000001	
XXX ± 37500.000	1:0.000000005	1:0.000000005	
XXX ± 45000.000	1:0.000000002	1:0.000000002	
XXX ± 50000.000	1:0.000000001	1:0.000000001	
XXX ± 60000.000	1:0.0000000005	1:0.0000000005	
XXX ± 75000.000	1:0.0000000002	1:0.0000000002	
XXX ± 90000.000	1:0.0000000001	1:0.0000000001	
XXX ± 100000.000	1:0.00000000005	1:0.00000000005	
XXX ± 125000.000	1:0.00000000002	1:0.00000000002	
XXX ± 150000.000	1:0.00000000001	1:0.00000000001	
XXX ± 180000.000	1:0.000000000005	1:0.000000000005	
XXX ± 200000.000	1:0.000000000002	1:0.000000000002	
XXX ± 250000.000	1:0.000000000001	1:0.000000000001	
XXX ± 300000.000	1:0.0000000000005	1:0.0000000000005	
XXX ± 375000.000	1:0.0000000000002	1:0.0000000000002	
XXX ± 450000.000	1:0.0000000000001	1:0.0000000000001	
XXX ± 500000.000	1:0.00000000000005	1:0.00000000000005	
XXX ± 600000.000	1:0.00000000000002	1:0.00000000000002	
XXX ± 750000.000	1:0.00000000000001	1:0.00000000000001	
XXX ± 900000.000	1:0.000000000000005	1:0.000000000000005	
XXX ± 1000000.000	1:0.000000000000002	1:0.000000000000002	
XXX ± 1250000.000	1:0.000000000000001	1:0.000000000000001	
XXX ± 1500000.000	1:0.0000000000000005	1:0.0000000000000005	
XXX ± 1800000.000	1:0.0000000000000002	1:0.0000000000000002	
XXX ± 2000000.000	1:0.0000000000000001	1:0.0000000000000001	
XXX ± 2500000.000	1:0.00000000000000005	1:0.00000000000000005	
XXX ± 3000000.000	1:0.00000000000000002	1:0.00000000000000002	
XXX ± 3750000.000	1:0.00000000000000001	1:0.00000000000000001	
XXX ± 4500000.000	1:0.000000000000000005	1:0.000000000000000005	
XXX ± 5000000.000	1:0.000000000000000002	1:0.000000000000000002	
XXX ± 6000000.000	1:0.000000000000000001	1:0.000000000000000001	
XXX ± 7500000.000	1:0.0000000000000000005	1:0.0000000000000000005	
XXX ± 9000000.000	1:0.0000000000000000002	1:0.0000000000000000002	
XXX ± 10000000.000	1:0.0000000000000000001	1:0.0000000000000000001	
XXX ± 12500000.000	1:0.00000000000000000005	1:0.00000000000000000005	
XXX ± 15000000.000	1:0.00000000000000000002	1:0.00000000000000000002	
XXX ± 18000000.000	1:0.00000000000000000001	1:0.00000000000000000001	
XXX ± 20000000.000	1:0.000000000000000000005	1:0.000000000000000000005	
XXX ± 25000000.000	1:0.000000000000000000002	1:0.000000000000000000002	
XXX ± 30000000.000	1:0.000000000000000000001	1:0.000000000000000000001	
XXX ± 37500000.000	1:0.0000000000000000000005	1:0.0000000000000000000005	
XXX ± 45000000.000	1:0.0000000000000000000002	1:0.0000000000000000000002	
XXX ± 50000000.000	1:0.0000000000000000000001	1:0.0000000000000000000001	
XXX ± 60000000.000	1:0.00000000000000000000005	1:0.00000000000000000000005	
XXX ± 75000000.000	1:0.00000000000000000000002	1:0.00000000000000000000002	
XXX ± 90000000.000	1:0.00000000000000000000001	1:0.00000000000000000000001	
XXX ± 100000000.000	1:0.000000000000000000000005	1:0.000000000000000000000005	
XXX ± 125000000.000	1:0.000000000000000000000002	1:0.000000000000000000000002	
XXX ± 150000000.000	1:0.000000000000000000000001	1:0.000000000000000000000001	
XXX ± 180000000.000	1:0.0000000000000000000000005	1:0.0000000000000000000000005	
XXX ± 200000000.000	1:0.0000000000000000000000002	1:0.0000000000000000000000002	
XXX ± 250000000.000	1:0.0000000000000000000000001	1:0.0000000000000000000000001	
XXX ± 300000000.000	1:0.00000000000000000000000005	1:0.00000000000000000000000005	
XXX ± 375000000.000	1:0.00000000000000000000000002	1:0.00000000000000000000000002	
XXX ± 450000000.000	1:0.00000000000000000000000001	1:0.00000000000000000000000001	
XXX ± 500000000.000	1:0.000000000000000000000000005	1:0.000000000000000000000000005	
XXX ± 600000000.000	1:0.000000000000000000000000002	1:0.000000000000000000000000002	
XXX ± 750000000.000	1:0.000000000000000000000000001	1:0.000000000000000000000000001	
XXX ± 900000000.000	1:0.0000000000000000000000000005	1:0.0000000000000000000000000005	
XXX ± 1000000000.000	1:0.0000000000000000000000000002	1:0.0000000000000000000000000002	
XXX ± 1250000000.000	1:0.0000000000000000000000000001	1:0.0000000000000000000000000001	
XXX ± 1500000000.000	1:0.00000000000000000000000000005	1:0.00000000000000000000000000005	
XXX ± 1800000000.000	1:0.00000000000000000000000000002	1:0.00000000000000000000000000002	
XXX ± 2000000000.000	1:0.00000000000000000000000000001	1:0.00000000000000000000000000001	
XXX ± 2500000000.000	1:0.000000000000000000000000000005	1:0.000000000000000000000000000005	
XXX ± 3000000000.000	1:0.000000000000000000000000000002	1:0.000000000000000000000000000002	
XXX ± 3750000000.000	1:0.000000000000000000000000000001	1:0.000000000000000000000000000001	
XXX ± 4500000000.000	1:0.0000000000000000000000000000005	1:0.0000000000000000000000000000005	
XXX ± 5000000000.000	1:0.0000000000000000000000000000002	1:0.0000000000000000000000000000002	
XXX ± 6000000000.000	1:0.0000000000000000000000000000001	1:0.0000000000000000000000000000001	
XXX ± 7500000000.000			

SYN	REVISION	RECORD	DATE	APPROV.
1	RELEASED TO PRE-PRODUCTION EOH-1033			
A	REV PER EOH-2049		4/29/97	G.P.
B	REV PER EOH-5372		5/7/98	G.P.
C	REV PER EOH-8514			

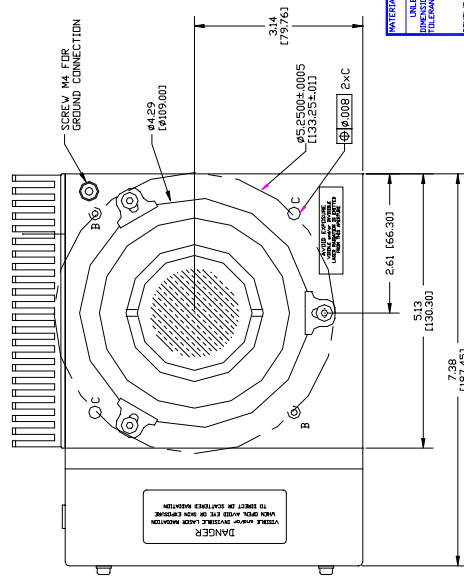
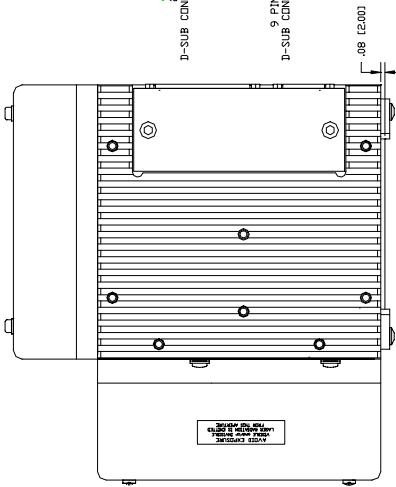
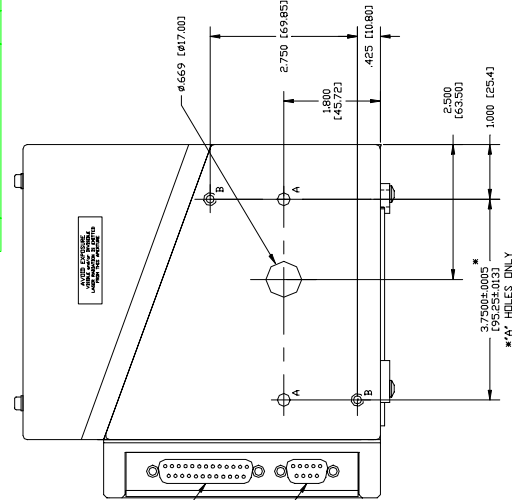
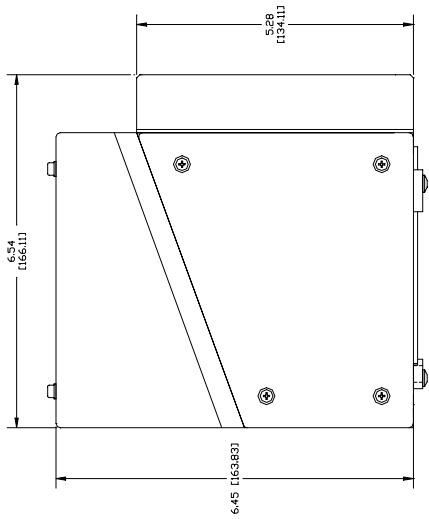

NOTES:
 ▲ DIGITAL VERSION FEMALE,
 ▲ ANALOG VERSION MALE.

HOLE	QTY	SIZE / THREAD	DEPTH
C	2	Ø2.390 \pm .0005 [60mm C11]	.24 [6.00]
B	4	M6	.24 [6.00]
A	2	Ø2.367 \pm .0005 [60mm F 8]	.24 [6.00]

MATERIAL		TREATMENT		CAD FILE NO.		ESN NO.	
UNLESS SPECIFIED	FUNCTION	NAME	DATE	CAD FILE NO.	GRANDVIEW/REP	ESN NO.	
DRAWN	BY	DATE	1/16/96				
CHECKED	BY	DATE	3/7/96				
DESIGNED	BY	DATE	3/7/96				
APPROVED	BY	DATE	3/7/96				

OUTLINE, HPMISM2
 f/200 HP CODE

360-17498 D

360-17498 D

SYM	REVISION	REASON	DATE	APP'D.
A	RELEASED TO PRODUCTION ECD-5138C			
B	REV PER ECD-8514			

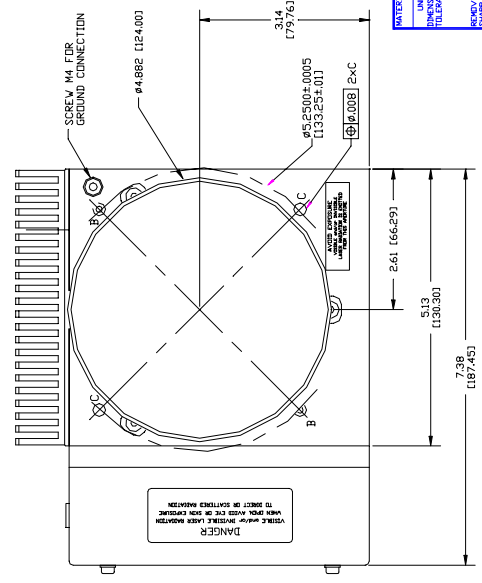
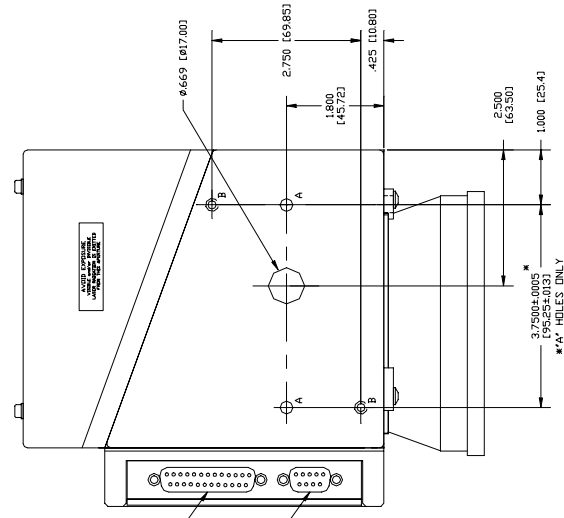
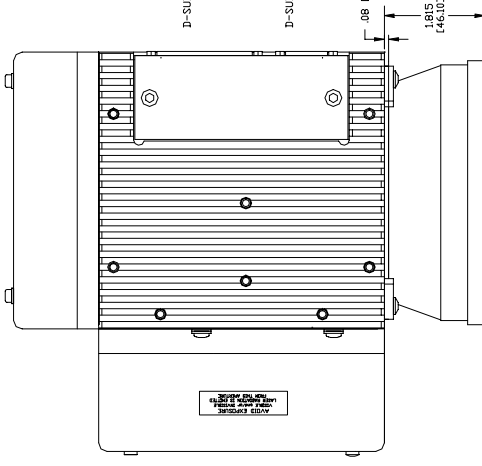
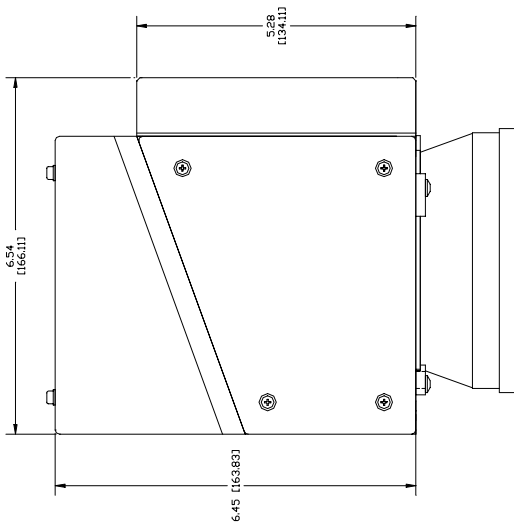

NOTES:
 ▲ DIGITAL VERSION FEMALE.
 ▲ ANALOG VERSION MALE.

HOLE	QTY	SIZE / THREAD	DEPTH
C	2	Ø.2370 - .0002 Gmm G11	.24 [6.00]
B	4	M6	.24 [6.00]
A	2	Ø.2367 - .0002 Gmm F8J	.24 [6.00]

MATERIAL		FUNCTION		DATE	FORM NO.
UNLESS SPECIFIED	316 STAINLESS STEEL	DESIGN	31-3106	3/16/79	001
TOLERANCES	AS SHOWN	CHECKER			
FINISHES	AS SHOWN	DATE			
STRAIGHTENING	AS SHOWN	DES. ENG.	S. PABLOTTI	3/20/78	
SPRUE	AS SHOWN	MFG. ENG.	S. PABLOTTI	3/20/78	
SCALE	1" = 1"	PROJ. MGR.			

OUTLINE, HPMSM2
 300 YAG

DRAWING NUMBER	ECD-20346	REV.	B
----------------	-----------	------	---

casiluminics
 VERLINDEN, MA

INDEX

- C—
 - Computer Requirements, 7
 - Customer Support, 3
- D—
 - Definition, 5
- F—
 - Federal Register, 10
- G—
 - Glossary, 23
- I—
 - Installation
 - HC/2, 15
 - HelperCard, 15
 - Interconnections, 16
- L—
 - Laser
 - Classes, 10
 - Hazard Zones, 11
 - Shutter Installation, 11
 - Shutter Location, 11
 - Warning Label, 10
 - Lens
 - Cleaning, 17
 - Mounting, 13
- M—
 - Maintenance
 - HPM15M2 Cleaning, 17
 - Lens Cleaning, 17
 - Mirror Cleaning, 18
 - Protection Glass Cleaning, 17
 - Mirror
 - Cleaning, 18
- P—
 - Power Supply
 - Specifications, 7
 - Protection Glass
 - Cleaning, 17
- S—
 - Specifications
 - Environmental, 7
 - Mirrors, 7, 26
 - Power Supply, 7
 - Scan Head, 7, 25
- T—
 - Troubleshooting, 21
- W—
 - Warranty, 2
- X—
 - XY15M2
 - Lens Mounting, 13
 - Mirror Specifications, 26
 - Mounting, 14
 - Pin Configurations, 27
 - Specifications, 25