

# ***GSI LUMONICS***

**XY2026M3ST Open Frame  
Hardware Manual  
ANALOG INTERFACE With DAE  
Open Frame Scan Head**

**60 Fordham Road  
Wilmington, Massachusetts 01887**

## TABLE OF CONTENTS

<b>1. INTRODUCTION.....</b>	<b>1</b>
<b>1.1 Warranty.....</b>	<b>2</b>
<b>1.2 Customer Support.....</b>	<b>3</b>
<b>1.3 Unpacking.....</b>	<b>3</b>
<b>2. GENERAL DESCRIPTION.....</b>	<b>4</b>
<b>2.1 Theory of Operation.....</b>	<b>4</b>
<b>2.2 General Description.....</b>	<b>5</b>
<b>2.3 Specifications.....</b>	<b>6</b>
<b>3. SAFETY AND WARNINGS.....</b>	<b>7</b>
<b>3.1 Laser Shutter Installation.....</b>	<b>9</b>
<b>3.2 Installation Safety Requirements.....</b>	<b>10</b>
<b>4. INSTALLATION.....</b>	<b>11</b>
<b>4.1 Mounting the Scan Head Frame.....</b>	<b>11</b>
<b>5. HANDLING/ MAITENANCE.....</b>	<b>12</b>
<b>5.1 Mirror Cleaning.....</b>	<b>12</b>
<b>6. TROUBLESHOOTING.....</b>	<b>14</b>
<b>7. GLOSSARY.....</b>	<b>15</b>
<b>8. APPENDIX A: Specifications.....</b>	<b>16</b>
<b>8.1 Scan Head.....</b>	<b>16</b>
<b>8.2 Scan Head Mirrors.....</b>	<b>17</b>
<b>8.3 Scan Head Pin Configurations.....</b>	<b>18</b>

<b>8.4 Electronics.....</b>	<b>19</b>
<b>9. APPENDIX B: Technical Outline Drawing .....</b>	<b>20</b>

# **XY2026M3ST Scan Head Analog Interface**



# Hardware Manual

## 1. INTRODUCTION

This manual details the instructions on how to install and operate hardware of the **Scan Head (Analog Interface)**. Included is information on setting up the hardware in preparation for your software commands, at which point you can refer to the proper software manual. Be careful to observe the information in the Environmental Requirements section that alert you to the hazards and the laser beam path you can expect while running the.

The **Scan Head** is **extremely intricate**, and since it consists of the galvanometers that reflect the laser beam, it can be hazardous if certain precautions are not taken. Please be alert to the safety considerations and specific procedures regarding the **Scan Head** and the laser you are using.

### *Conventions*

Throughout the manual you will see graphic icons representing pertinent information in the text. The purpose of these icons is to provide a visual convention to alert you of a stop in the flow of the manual, where an important note or safety hazard alert is posted.



**NOTE** is an important procedure you should be aware of before proceeding.

**CAUTION** alerts you of a potential danger to equipment or the user.

**WARNING** indicates an imminent danger to the user.

**TIP** and **REMINDER** are helpful hints to procedures listed in the text.

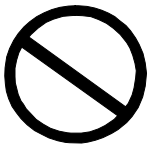
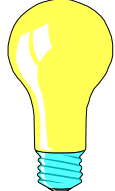
The conventions are listed as follows, showing both the text and the picture you will see.

NOTE	CAUTION	TIP	WARNING	REMINDER
				

# 1.1 Warranty

---

GSI LUMONICS (GSLI) warrants this product to be free from defects in materials and workmanship for 12 months from the date of shipment. GSLI will, at its option, repair or replace the product if it is defective within the warranty period and returned, freight pre-paid, to a service center designated by GSLI.

GSI LUMONICS requests that customers obtain a Return Authorization Number prior to returning units, and that they carefully pack units in their original packing or equivalent. Under warranty, GSLI is not obligated to repair damage to any units resulting from the following conditions (customers are responsible for defining which conditions are applicable to their product):

- a) Personnel other than GSLI representatives attempting to repair or service the product.
- b) Improper use of the equipment.
- c) Connecting the product to incompatible equipment.
- d) Personnel other than GSLI representatives modifying the product.
- e) Scratches and chips on any optical surface after three weeks from the date of receipt.
- f) Damage to any optical surface from improper handling or cleaning procedures. This applies specifically to those items subjected to excess laser radiation, contaminated environments, extreme temperature or abrasive cleaning.

Customers assume all responsibility for maintaining a laser-safe working environment. OEM customers must assume all responsibility for **CDRH** (Center for Devices and Radiological Health) certification.



NOTE

**There is no implied warranty of fitness for a particular purpose, and GSLI is not responsible for consequential damages. Individual components manufactured by GSI or others may be covered by their own warranties. Refer to the appropriate manuals for this information.**

---

---

## 1.2 Customer Support

---

GSI LUMONICS has support services available to you concerning problems with either the product or manual you are using.

Before calling for assistance, please make sure you refer to any appropriate sections in the manual that may answer your questions. The “Outline Drawings / Data Sheets” in

Appendix B may be particularly helpful. If you need further assistance:

The customer service personnel will be able to give you direct assistance and answers to your questions.



<b>U.S. (Massachusetts):</b>	<b>978-661-4300 (in the U. S.)</b> <b>+01 978-661-4300 (outside the U. S)</b>
<b>Germany (Munich):</b>	<b>+49 89 899134-0</b>
<b>UK (Banbury):</b>	<b>+44 132 787 2424</b>
<b>Japan (Tokyo):</b>	<b>+81 3 3406 7990</b>

*... ask for the GMAX Customer Service Department*

## 1.3 Unpacking

---

The package you receive will include those items mentioned in the packing list is included in the shipment that details the exact items shipped.

- a) CAREFULLY unpack the contents from the box.
- b) Save shipping container and packaging material in case you need to return unit for service.
- c) Check contents of the box against the packing list to assure all parts have been received.
- d) Inspect each item to assure it is not damaged.

# 2. GENERAL DESCRIPTION

## 2.1 Theory of Operation

---

The High Performance Open Frame Laser Scanning Module is a multi-purpose-designed module. The module consists of 2 galvanometer scanners (X and Y), optics (flat field lens) and external Dual Axis Digital Driver Electronics.

GSI LUMONICS 2-mirror, 2-axis galvanometer Scan Heads provide the capability of deflecting optical beams in an XY manner for all possible laser applications. The synchronized actions of two galvanometer servo-controlled turning mirrors direct the laser beam to specific locations on a target material surface in both the X and Y directions.

**PC-MARK MT** and **JOB EDITOR** (optional), sophisticated laser control software, controls the motion of the galvanometer according to the design selected by the user. The external driver electronics and the **HC/2** card are connected through a 25-pin inter-connecting cable.

## 2.2 General Description

---

The **Scan Head (Analog Interface)** is a basic building block for the construction of a laser beam positioning system, It is intended for use by OEM customers, integrators, and sophisticated end-users.

The  $\pm 5$  V analog interface has separate signal inputs for X- and Y-axis. Status signals provide indications of a fault of the X- or Y-axis.

$\pm 15$  V Input:                    9 pin D sub connector male, mounted on the Scan Head  
Interface Connector :        25 pin D sub connector male, mounted on the Scan Head

**GSI LUMONICS provides the following items that make up the Scan Head package:**

- Scan Head with 2 galvanometer scanners, optics and integrated driver electronics.
- Documentation.

**The Customer must provide:**

- A laser.
- A computer
- A method of mounting the Scan Head
- An analog interface cable
- Power supply with the following specifications:

*Power Supply  
Specifications*

Voltage V1/V2	$\pm 15$ V +60%-20%
Current	2A
Ripple	$\leq 0.2\%$
Noise	$\leq 0.5\%$ DC to 30MHz

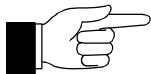

**NOTE**

- The supplies need to be capable of supplying the necessary current for the galvos, the heater systems and the electronics.

## 2.3 Specifications

---

### *Environmental Requirements*

Storage Temperature:	-10°C to +60°C
Minimum Operation Temperature:	+15°C
Maximum Operating Temperature:	+34°C
Humidity:	Non-condensing

### *Scan Head*

Specifications and Pin Configurations are located in “APPENDIX A: Specifications”.

### *Mirrors*

Specifications are located in “APPENDIX A: Specifications”.

---

---

# 3. SAFETY AND WARNINGS

The United States Food and Drug Administration, through the Center for Devices and Radiological Health (CDRH), has promulgated regulations (21 CFR parts 1000 and 1040) controlling the safety of lasers and laser products for sale or manufacture in the United States. GSI LUMONICS **XY Scan Heads** are regulated by the CDRH.

This section is a guide to the specific areas of this product and to the manual(s). Pay particular attention to CDRH compliance information.

GSI LUMONICS **XY Scan Head** are designed to provide maximum flexibility and ease of use. Such a design inherently requires the user to assure the overall safety of the configuration in use.

It is the user's responsibility to insure that:

- 1) Only lasers certified to comply to CDRH regulations are used with GSI LUMONICS **XY Scan Heads**.
- 2) Certified lasers contain features to assist in their safe usage. These protective features and the protective features within the GSI LUMONICS **XY Scan Heads** should not be defeated.

**Prior to operating any configuration of the GSI LUMONICS XY Scan Heads, you must make a through analysis of system safety. Key information for this purpose is contained in this manual. You would thoroughly familiarize yourself with all this information before proceeding.**



CAUTION

A full description of laser hazard analysis is beyond the scope of this manual. A good technical survey of laser safety requirements can be found in ANSI Z136.1, "American National Standard For the Safe Use of Lasers". This is available from:

*American National Standards Institute, Inc.  
1430 Broadway  
New York, New York 10018*

Among the many other sources of laser safety information, the following institution offers several excellent publications.:

*The Laser Institute of America  
5151 Monroe Street, Suite 118W  
Toledo, Ohio 43623*

Final analysis of all safety features should be made by your Laser Safety Officer or a competent specialist in this field.

The first consideration in a safety analysis is the laser mated to the GSI LUMONICS **XY Scan Head**. The hazard level of the laser is roughly indicated by the Laser Class label that is on the device. A brief description of the radiation classes are shown in the following table.

Note that, besides radiation, lasers may present other hazards, e.g.; electric shock or creation of poisonous fumes.

*User  
Responsibilities*

*Laser Hazard Analysis*

*Classes and Characteristics of Lasers*

LASER CLASS	DESCRIPTION
<b>Class I</b>	Lasers are not considered to be hazardous.
<b>Class IIa</b>	Lasers are hazardous if viewed for periods greater than one thousand seconds.
<b>Class II</b>	Lasers are chronic viewing hazards.
<b>Class IIIa</b>	Lasers may represent acute, intrabeam viewing or chronic or acute viewing hazards when viewed with optical instruments.
<b>Class IIIb</b>	Lasers are an acute hazard to skin and eyes from direct radiation.
<b>Class IV</b>	Lasers are an acute hazard to skin and eyes from direct or scattered radiation.



**CAUTION**

Do not use equipment outside of these ranges, as additional hazards may result.

Because we do not determine the laser used with our product, all GSI LUMONICS end-user **XY Scan Heads** are labeled at the highest hazard level (Class IV). You should obtain information on output power or energy, wavelength(s) of output, duration of pulse, beam size and beam divergence from the manufacturer of the laser you are using.

The wavelength and power of the laser actually used should be written on the warning logo type label, Position 2. (See Section page 33699 and 33700 of the Federal Register, Appendix B). Be sure to use a permanent, indelible ink.

*Class IV Warning Label*

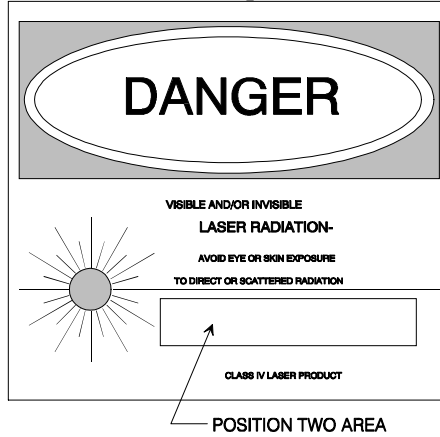

The Federal Register Rules and Regulations, Vol. 50, No. 161, dated Tuesday, August 20, 1985, contains the performance standards adopted by the Food and Drug Administration (FDA) which gives detailed information regarding the determination of laser classification and labeling. The ANSI and the FDA classifications are not the same. For purposes of labeling, use only the FDA classifications. If your laser falls in a classification below Class 4, replace the warning label type with the correct label and appropriate classification. The factory provides alternate labels upon request.

The GSI LUMONICS **XY Scan Heads** provide you with the ability to aim the laser beam over a roughly pyramidal volume. The divergence of the focused beam beyond the focal point, which is a function of the lenses selected and their position, can cause radiation to exit the pyramid. When analyzing safety, you must consider all regions within this aiming pyramid the divergent beam, and the effects of all focal possibilities in the zone of hazard. Reflections must also be considered.



**REMINDER**

### 3.1 Laser Shutter Installation



The laser attenuator (shutter) is not included with the **XY Scan Head**. Because each laser is unique, it is the user's responsibility to insure that such a device is incorporated in the installation in conformance with CFR regulations (1040.10[f][6]), which reads as follows: A beam attenuator is required on Class II, IIIa, IIIb and IV laser systems. The beam attenuator is a mechanical or electrical device such as a shutter or attenuator that blocks emission. The beam attenuator blocks bodily access to laser radiation above Class I limits without the need to turn off the laser. The beam attenuator must be available for use at all times during operation. Power switches and key controls do not satisfy the attenuator requirement.

*Example of Laser Shutter Location in a HPLK System*

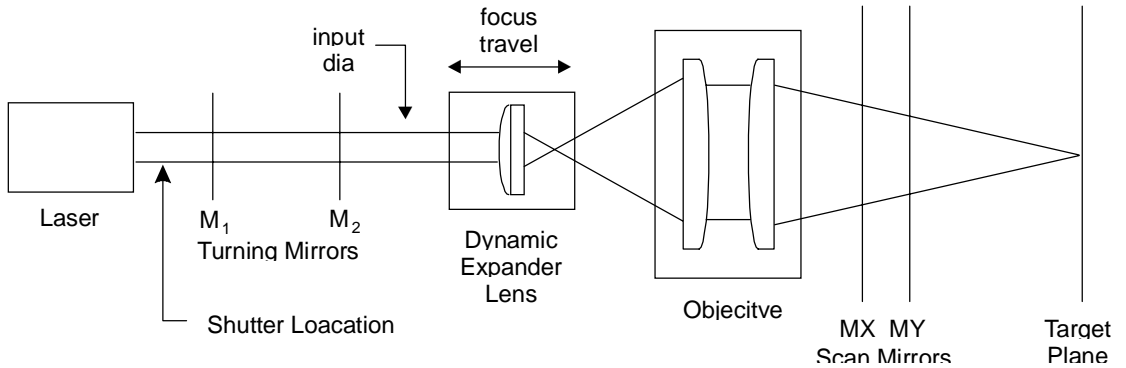

The beam shutter should be installed between the laser head and the Scan Head. The following figure shows the recommended location of the shutter.



We strongly recommend that you specify a laser with a vendor-supplied shutter mechanism. If this is not possible, consult the laser vendor to design a proper safety shutter.

*Laser Scanner Hazard Zones of an HPM Scan Head*

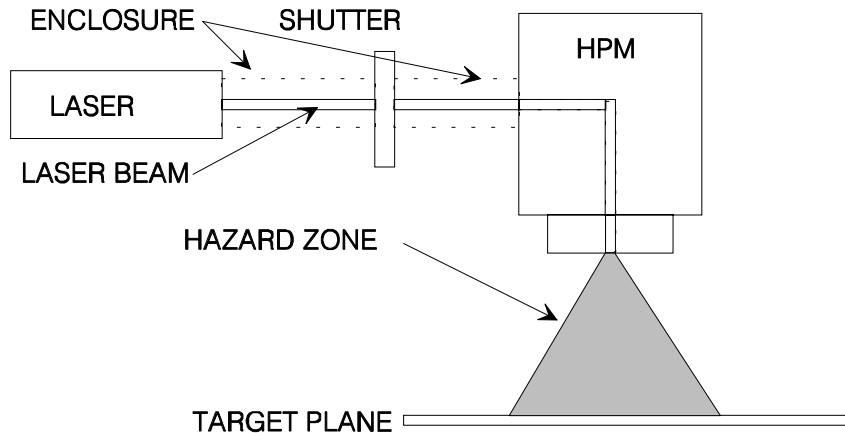

The figure shows the laser's internal and external optical path towards the target plane, specifically where the hazard zones are located as the optical beam passes

## 3.2 Installation Safety Requirements

---

Because of the possible hazard increase of scanning stopping or slowing to an unsafe velocity, it is required that the controller software shuts down the laser power (a scanning safeguard).

In all cases, we recommend that you fully enclose and interlock the zone of hazard for your application to prevent possible opening while the laser is energized. When laser radiation exceeding Class 1 levels may exit the enclosure, you must have suitable protection for eyes available.



NOTE

**At no time should you stare into the beam, place any parts of your body in the beam path, or expose yourself to reflections of powerful beams. You should use only a Class 1 HeNe Laser for alignment. If this is not possible, you should use the available laser's lowest power setting and remote beam sensing technique.**



CAUTION

**Using optical instruments with this product increases eye hazard.**

Additional Safety requirements may be applicable during initial alignment of the optical system. Refer to Section, “Safety and Warnings”, Section 3.

GSI LUMONICS XY Scan Heads are labeled in conformance to the requirements of 21 CFR parts 1000 and 1040.



# 4. INSTALLATION

## *Installation Safety Requirements*



**WARNING**

**W**e recommend that you fully enclose and interlock the zone of hazard for your application to prevent possible opening while the laser is energized. If laser radiation exceeding Class 1 levels may exit the enclosure, you must have available suitable protection for your eyes.

At no time should you stare into the beam, place any parts of your body in the beam path, or expose yourself to reflections of powerful beams. You should use only a class I HeNe laser for alignment. If this is not possible, you should use the available laser's lowest power setting and remote beam sensing technique. Using optical instruments with this product increases eye hazard.

Additional Safety requirements may be applicable during initial alignment of the optical system. See the next section for specific safety information. GSI LUMONICS **XY15M2** Scan Heads are labeled in conformance to the requirements of 21 CFR parts 1000 and 1040.

## 4.1 MOUNTING THE SCAN HEAD FRAME

- 1) The Scan Head requires a mounting plate that will match the mounting pins and holes on the bottom of the Scan Head Frame. The outline drawings, in Appendix C, can be used to determine the dimensions for manufacturing a mounting plate.
  - 2) Line up the Scan Head module dowel holes with the dowel pins which protrude from your mounting
  - 3) Install the Scan Head module onto the pins.
  - 4) Insert appropriate size cap screws into the holes of the mounting flange. The screw length should be long enough to provide three or more full turns into the tapped holes.
  - 5) Using an allen wrench, tighten the screws. Alternate tightening the screws so that the Scan Head comes together evenly with the mounting plate.
- 
-

# 5. HANDLING / MAINTENANCE

The GSI LUMONICS XY Scan Head does not contain any user serviceable or user maintainable parts. However, you should visually inspect all optical surfaces each time lenses and alignment mirrors are handled.



**Make sure that the laser is off before performing any inspections! Wear finger cots or cotton gloves when handling optics for inspection.**

All contamination on optical surfaces must be removed prior to operation or serious damage and/or hazard may result. The Scan Head must be protected from airborne contaminants. Dust attaching through impact or heating and vapors condensing on the optical surfaces reduces the mirror's reflectivity. Furthermore, avoid scanner exposure to dust, condensation or cleaning fluids in the exposed bearing area.



**You must be extremely careful not to allow contamination from entering the galvanometer through its exposed bearing. Serious scanner damage may result.**

If you feel that cleaning or service is necessary, contact the customer service group at GSI LUMONICS for information regarding service.

## 5.1 Mirror Cleaning

---

Although the mirrors can be replaced by the user, we do **not recommend** you do so. Furthermore, **General Scanning does not recommend cleaning front surface mirrors.** Mirrors damaged by cleaning are not included under the warranty. The surface of these mirrors damages easily. It is difficult to prevent hard dust particles from being entrained in the process and causing scratches. In many cases, small defects in the mirror's surface may be less harmful than the surface damage resulting from continued cleaning. It requires special equipment typically not available to customers.

There are times, however, when cleaning the mirror becomes a necessity, e.g. stains such as fingerprints must be removed immediately to prevent permanent etching of the reflective surface. The information below includes general recommendations for those special occasions when mirrors must be cleaned.

### *Removing Dust*

Remove lint from mirrors with a jet of low pressure clean air. Blowing on front surface mirrors deposits moisture that may stain the finish.

---

---

## Removing Stains

A thin overcoating of silicon monoxide protects most mirrors from oxidation. Like many optical coatings, it is easily damaged when attempts are made to clean the mirror surface with a dry tissue.

The safest method of cleaning is to place a piece of lens tissue on the mirror surface and wet it with reagent grade (highly pure) alcohol or acetone (If you use acetone, take precautions regarding possible health and fire hazards). Grasp an overhanging corner of the tissue and gently agitate it several times, then slide the tissue off. This should remove the problem blemishes.



CAUTION

**Do not let solvent enter the bounding zone of the mirror.**

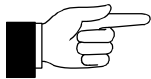

NOTE

**Note that the mirror is not rubbed.**

If the mirror surface is still contaminated, use a highly pure solvent such as alcohol or acetone and generously wet the mirror surface with a **sterile** cotton swab or lens tissue. Gently wipe the dirty areas. Turn your cotton swab or tissue with each stroke so that a clean area is exposed.



CAUTION

**Do not let solvent enter the scanner bearings. When wetting the mirror's surface, hold the scanner at an angle so that the liquid does not wet the scanner. If any solvent is found in the bearings of the scanner, the warranty is voided.**

---

---

## 6. TROUBLESHOOTING

If you encounter problems with your **Scan Head**, you can check the following matrix. If you cannot solve the problem, contact **GSI LUMONICS** for further assistance.

PROBLEM	PROBABLE CAUSE	POSSIBLE SOLUTION
1. Decrease in marking quality.	1. Dirty protection glass.	1. Clean glass per instructions in Maintenance Section.
	2. Drop in output power.	1. Check laser power.
2. Laser will not mark when ordered by computer.	1. Laser modulation malfunction.	1. Check connections between laser controller and laser.
	2. No power to galvanometers.	1. Check power connections to scanning head.

# 7. GLOSSARY

- Galvanometer:* A scanner with limited rotation magnetic torque motor with position feedback. The galvanometer (galvo) rotates a mirror to direct the laser beam.
- HC/2:* A PC based board that provides the hardware link between your PC and the XY Industrial Scan Head. I/O for laser control and parts handling are additional features. The HC/2 is fully compatible with PC-MARM MT (multitasking) software.
- HPGL:* HP® Graphics Language, a graphics format which PC-MARK MT can translate into vector data for scanning.
- HPM:* (High Performance Modules) Complete beam position packages consisting of the XY Industrial Scan Head, Driver Electronics, PC resident HC/2 card, PC-MARK MT software and interconnects.
- I/O-2:* An add-on board available as an option to the HC/2 card. Features include opto-isolated programmable I/O ports, analog laser power control and first pulse suppression.
- PC-MARK MT:* (multitasking) A powerful front-end macro command language. PC-MARK MT accepts application commands to place text and graphics in the marking field and translates them into the appropriate lists of vectors. Users may also write their own PC-MARK MT programs in any one of many popular software languages. MMCL is utilized as the link to the HC/2 card.
- JOB EDITOR:* A menu-driven application program of PC-MARK MT that provides an extensive graphics user interface and file management. It allows the user to manipulate HPGL based graphics with an accurate real preview of one's job.
- 
-

# 8. APPENDIX A: Specifications

## 8.1 XY Series Scan Head

---

These specifications are not defined yet.

<b>Laser Type</b>					
<b>Wavelength</b>					
<b>Objective (f in mm)</b>					
<b>Standard Field Size (mm<sup>2</sup>)</b>					
<b>Maximum Practical Field Size (mm<sup>2</sup>)</b>					
<b>Spot Size TEM<sub>00</sub> (μm)</b>					
<b>Working Distance (mm)</b>					
<b>Resolution (μm)</b>					
<b>Writing Speed (m/s)</b>					
<b>Uncalibrated Non-Linearity (maximum %)</b>					
<b>Temperature Drift (maximum μm/°C)</b>					
<b>Aperture (mm)</b>					
<b>Scan Angle (maximum)</b>					
<b>Power Capability, cw (W/cm<sup>2</sup>)</b>					
<b>Power Capability, 100 ns pulsed (MW/cm<sup>2</sup>)</b>					
<b>Scan Head Size (height x length x with in mm)</b>					
<b>Weight (kg)</b>					

## 8.2 Scan Head Mirrors

	LASER TYPE					
	YAG	CO2	ARGON	ARGON (HP)	UV	VISIBLE
<b>Wavelength</b>	1,064 nm	10,600 nm	488-514 nm	488-514 nm	325-360 nm	450-700 nm
<b>Coating</b>	Dielectric	Dielectric on Metal	Dielectric	Dielectric	Dielectric	Durable Ag
<b>Reflection (min.) @ Wavelength (nm)</b>	99.5% @ 1,064 80.0% @ 450-650	99.5%	98.0% @ 480-514 50.0% @ 633	99.5%	98.0% @ 325-350 95.0% @ 350-360 45.0% @ 633	96.0%
<b>Flatness @ 633 nm</b>	$\lambda/4$	$\lambda/4$	$\lambda/4$	$\lambda/4$	$\lambda/4$	$\lambda/4$
<b>Power Capability, cw (W/cm<sup>2</sup>)</b>	500	500	100	5 MW/cm <sup>2</sup>		10
<b>Power Capability, 100 ns pulsed (MW/cm<sup>2</sup>)</b>	100	400	80	2 GW/cm <sup>2</sup> (10 ns pulsed)		N/A
<b>Surface Quality (Scratch/Dig)</b>	40/20	40/20	40/20	40/20	40/20	40/20

See your GSI LUMONICS sales representative for more details.



## 8.4 Electronics

---

### 8.4.1 Analog Interface

---

The Analog interface consists of two sets of differential input lines for the X-axis and the Y-axis. The required input for a full field deflection is  $\pm 5\text{ V}$  (+5% -0%). The required input has to be in the specified range, because there are no adjustments available for the input on the Scan Head electronics.



*Differential Input*

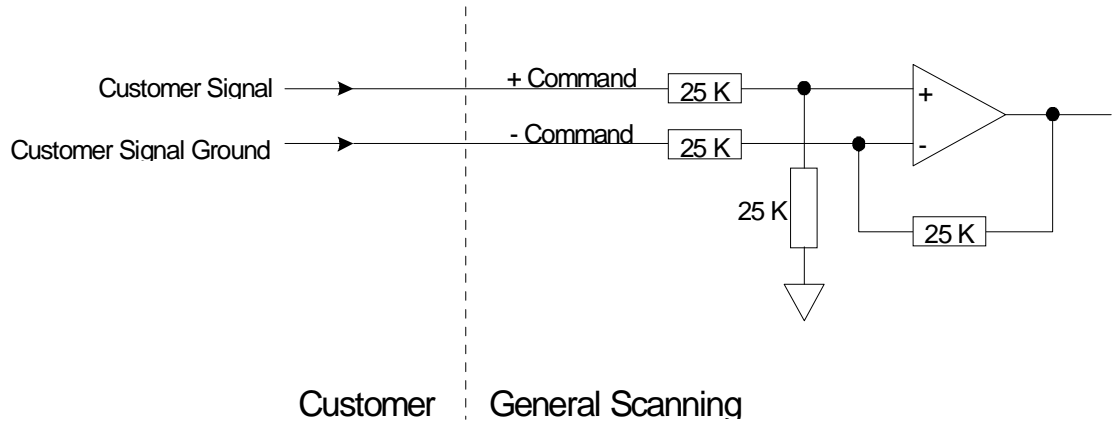

### 8.4.2 Flags Interface

---

There are two flags (/XERROR and /YERROR) available from the electronics.

If /XERROR or /YERROR occurs, please check that:

- the X- or Y-scanner position is within the working field (analog input voltage is  $\pm 5\text{ V}$  +5% -0%), and
- the input power supply ( $\pm 15\text{ V}$  +60%-20%) for the Scan Head is correct.

If both are correct then call our technical service.

Both flags are low active and have to be pulled up on the customer side to the desired voltage.

---

---

*Flag Output*

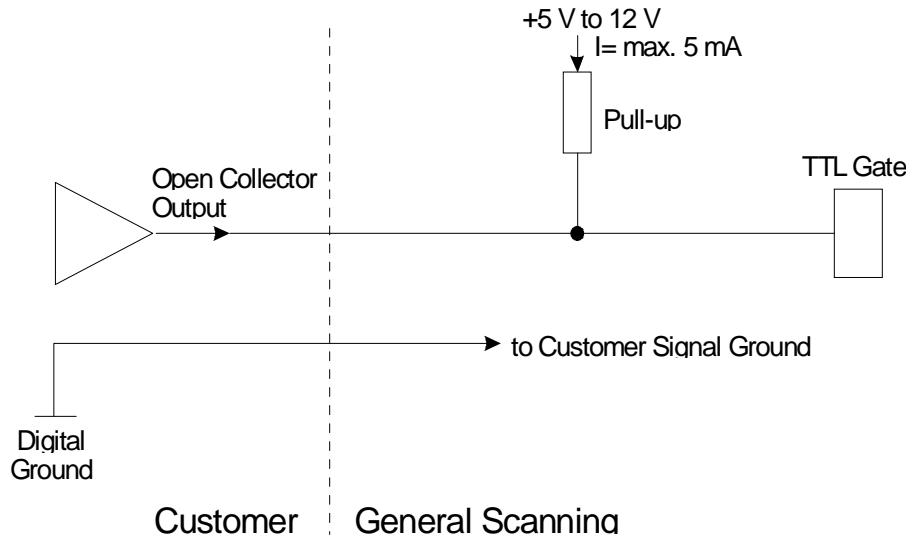

## 9. APPENDIX B: Technical Outline Drawings

- Outline, XY2026M3ST Open Frame DWG #: ECD-20334
- Outline, XY2026M3ST Open Frame DWG #: ECD-21498



PROPERTY OF CSI LUMONICS  
 This document is and shall remain an unreplicated work of CSI LUMONICS, protected by copyright. It is to be used only for the specific project and shall not be reproduced, stored in a retrieval system, or transmitted in any form or by any means, electronic, mechanical, photocopying, recording, or by any information storage and retrieval system, without the prior written consent of CSI LUMONICS.

SYM	REVISION	RECORD	DATE	APPROV'D.
1	RELEASED TO PRE-PROD	ECN-51254		
2	REV PER	ECO-9107		

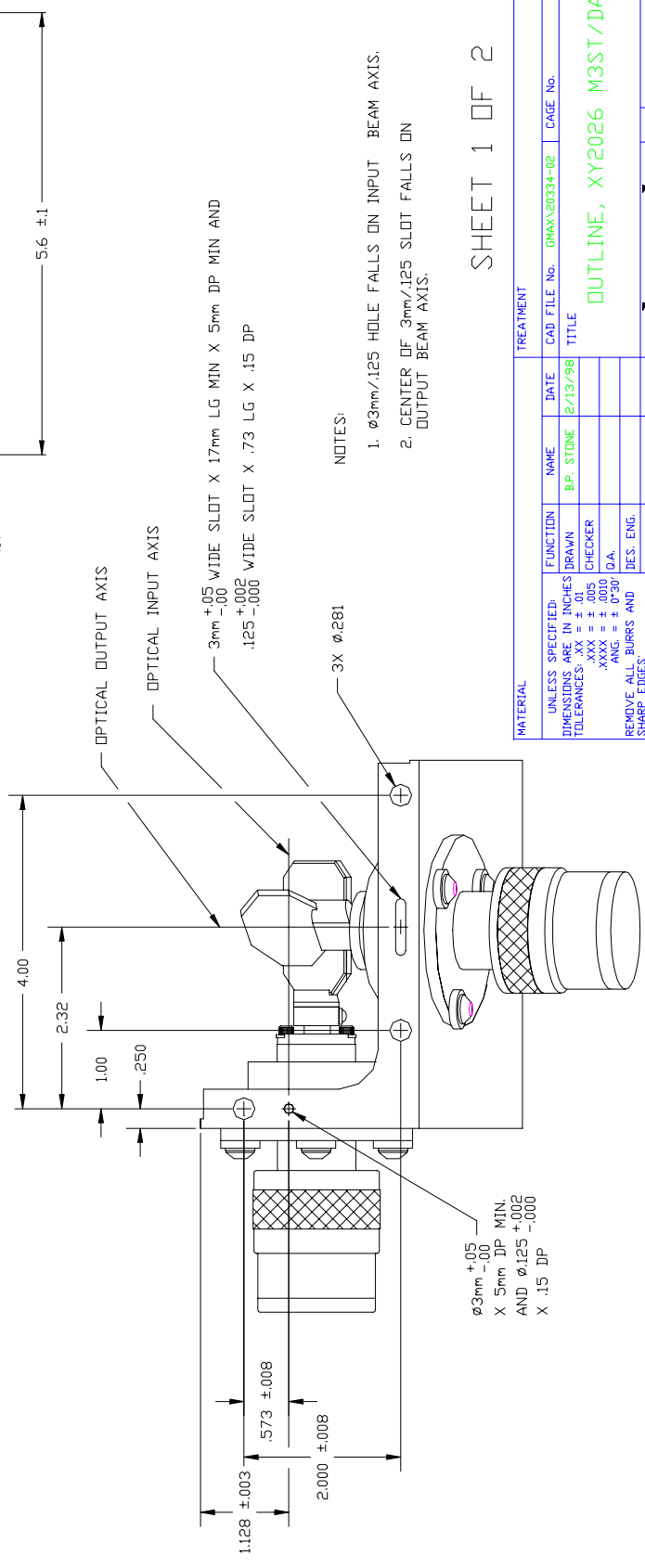
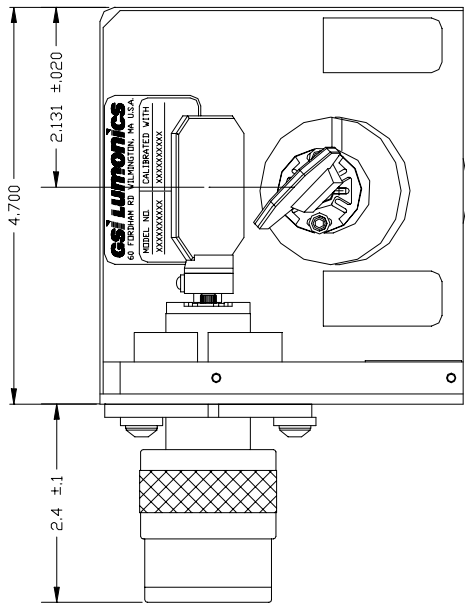
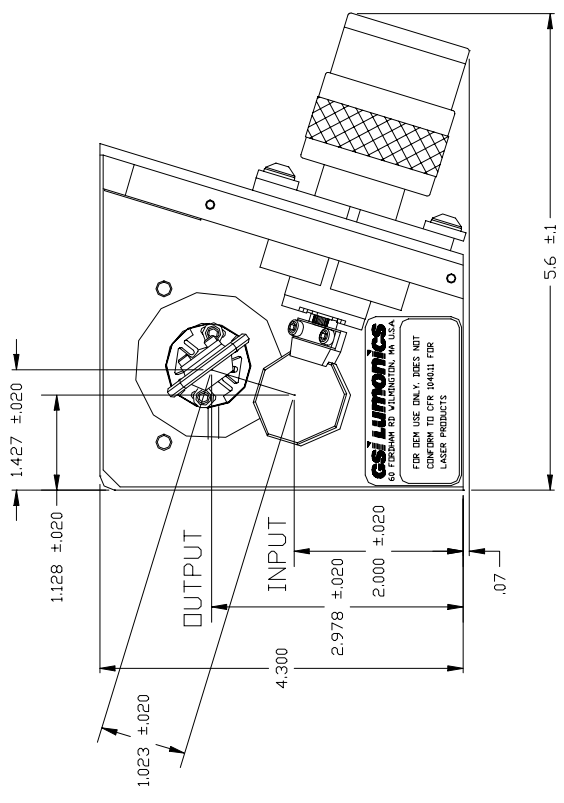

- NOTES:
- Ø3mm/.125 HOLE FALLS ON INPUT BEAM AXIS.
  - CENTER OF 3mm/.125 SLOT FALLS ON OUTPUT BEAM AXIS.

SHEET 1 OF 2

MATERIAL		TREATMENT	
UNLESS SPECIFIED:	FUNCTION	NAME	DATE
DIMENSIONS ARE IN INCHES	DRAWN	BP. STONE	2/13/98
TOLERANCES:	CHECKER		
.XXX ± .005			
.XXXX ± .0010			
ANG. = ± 0°30'			
REMOVE ALL BURRS AND SHARP EDGES	DES. ENG.	G. PAOLUCCI	2/20/98
SCALE: [ ] = [ ]	MFG. ENG.		
	PROJ. MGR.		

CAD FILE NO.	GMAX.20334-02	CAGE NO.
TITLE	OUTLINE, XY2026 M3ST/DAE	

REV	DRAWING NUMBER	SIZE
2	ECD-20334	C

**CSI LUMONICS**  
 WILMINGTON, VA





PROPERTY OF GSI LUMONICS  
 This drawing is the property of GSI LUMONICS. It is to be used only for the purpose of manufacturing the product shown. It is not to be used for any other purpose. All dimensions are in inches unless otherwise specified. All tolerances are as indicated. All dimensions are to be held to the nearest 0.001 inch unless otherwise specified.

SYM	REVISION	RECORD	DATE	APPVD.
A	RELEASED TO PRODUCTION ECO-8142			
B	REV PER ECO-8405			

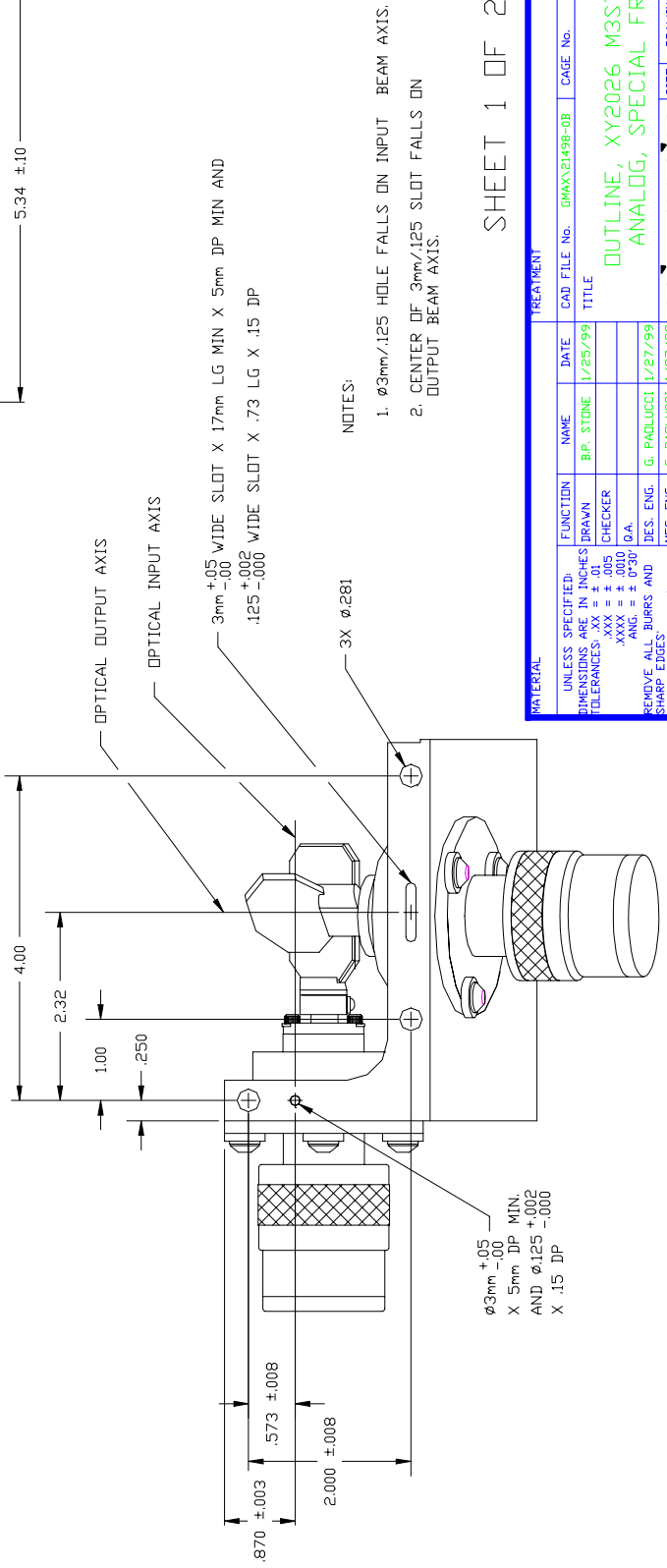
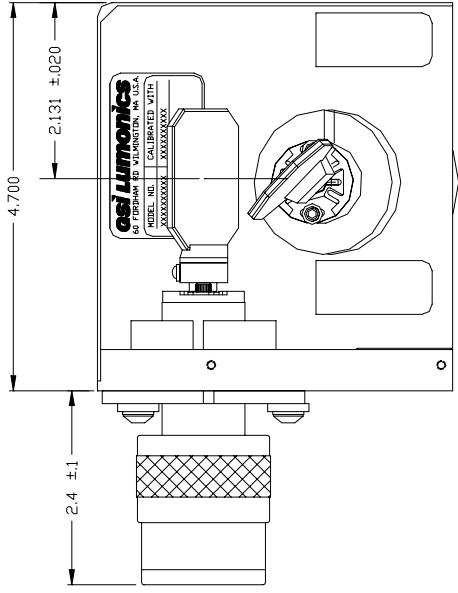
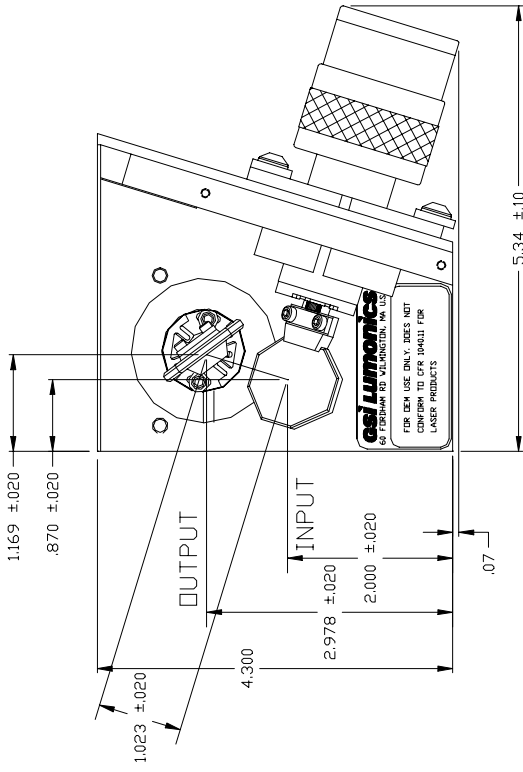

- NOTES:
- Ø.3mm/.125 HOLE FALLS ON INPUT BEAM AXIS.
  - CENTER OF 3mm/.125 SLOT FALLS ON OUTPUT BEAM AXIS.

SHEET 1 OF 2

MATERIAL		TREATMENT		CAGE No.	
UNLESS SPECIFIED:	FUNCTION	NAME	DATE	CAD FILE No.	GMAX-21498-08
DIMENSIONS ARE IN INCHES	DRAWN	B.P. STONE	1/25/99	TITLE	
TOLERANCES: .XX = ±.01	CHECKER				
.XXX = ±.005					
.XXXX = ±.0010					
ANG. = ±.0°30'					
REMOVE ALL BURRS AND SHARP EDGES	DES. ENG.	G. PAOLUCCI	1/27/99		
SCALE	MFG. ENG.	G. PAOLUCCI	1/27/99		
1:1	PROJ. MGR				

OUTLINE, XY2026 M3ST/DAE  
 ANALOG, SPECIAL FRAME

**GSI LUMONICS**  
 WILMINGTON, MA

SIZE: C  
 DRAWING NUMBER: ECD-21498  
 REV: B

SYM	REVISION	RECORD	DATE	APPV'D.
	SEE SHEET 1			

PROPERTY OF GSI LUMINICS  
 This document is confidential and its contents are the property of GSI LUMINICS. It is to be used only for the purposes intended and is not to be distributed, copied, or otherwise used without the written consent of GSI LUMINICS.

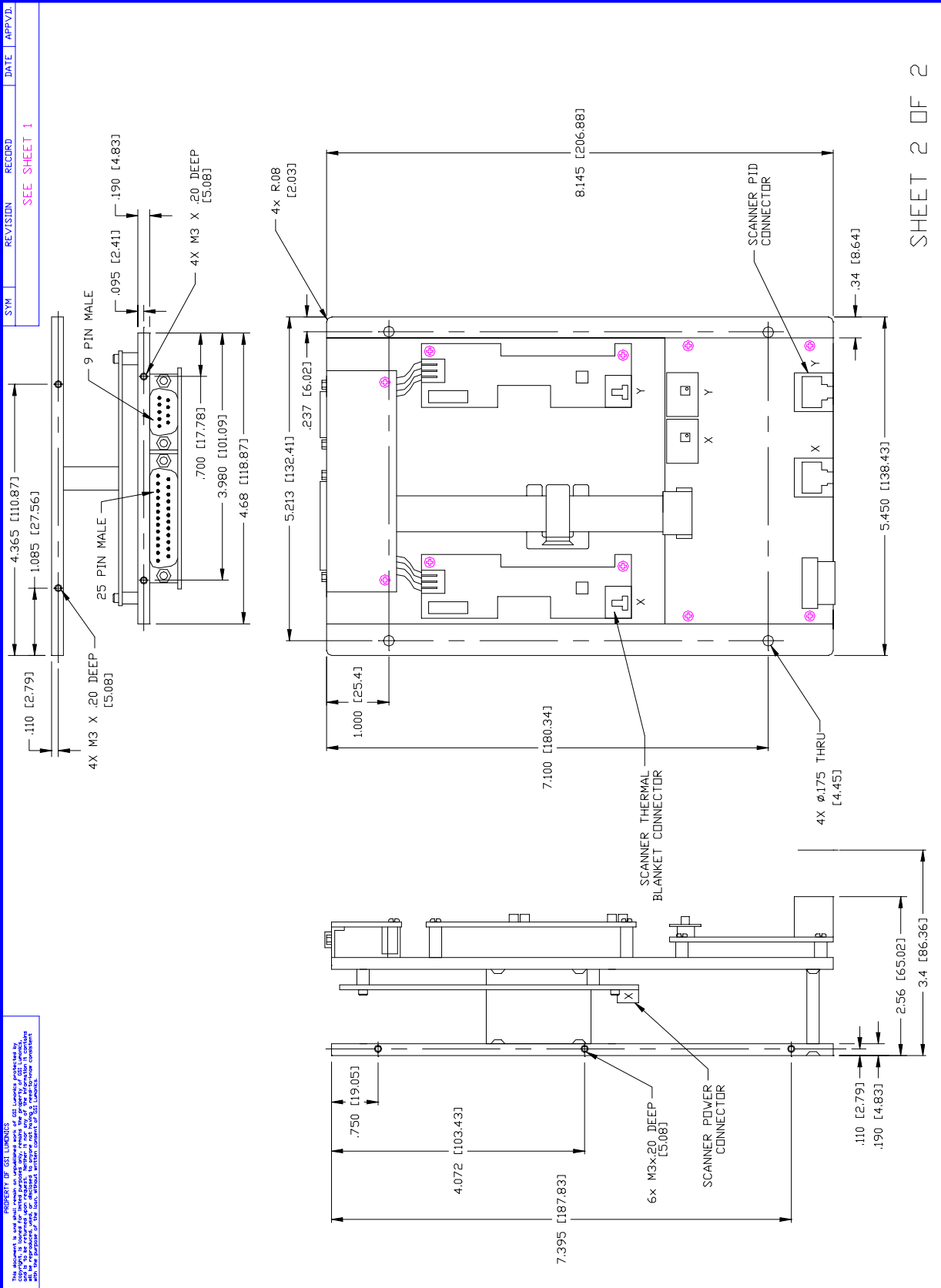

SCALE	CAD FILE No.	FSCM No.	SIZE	DRAWING NUMBER	REV
1=1	GMAX-21498-08		C	ECD-21498	B

REQUIRED SPACE WITH SCANNER CONNECTORS PLUGGED IN