

gsi Lumonics

**HPM10G4
Hardware Manual**

XY10G4 Scan Head

**60 Fordham Road
Wilmington, MA 01887**

gsi Lumonics

**GSIL P/N
E40-21502
REVISION C**

TABLE OF CONTENTS

1. INTRODUCTION	1
1.1 Warranty.....	2
1.2 Customer Support	3
1.3 Unpacking	3
2. HPM10G4 OVERVIEW	5
2.1 Theory of Operation	5
2.2 General Description.....	6
2.3 Specifications	7
3. SAFETY AND WARNINGS	9
3.1 Laser Shutter Installation.....	11
3.2 Installation Safety Requirements	12
4. INSTALLATION	13
4.1 Handling the XY10G4 Scan Head Lens.....	13
4.2 Mounting the XY10G4 Scan Head.....	14
4.3 HC/2 or HelperCard Installation.....	15
4.4 Interconnections.....	16
5. MAINTENANCE.....	17
5.1 Lens / Protection Glass Cleaning	17
5.1.1 Introduction	17
5.1.2 Basic Cleaning Procedure.....	17
5.1.2.1 Back-spatter / Burned-in Damage	18
5.2 Mirror.....	18
5.2.1 Cleaning Procedure	18
6. TROUBLESHOOTING.....	21
7. GLOSSARY	23
8. APPENDIX A: Specifications	25
8.1 XY10G4 Scan Head	25
8.2 XY10G4 Scan Head Mirror	26
8.3 XY10G4 Scan Head Pin Configurations	27
9. APPENDIX B: Technical Outline Drawings.....	28

High Performance Laser Scanning Module (HPM10G4) Hardware Manual

1. INTRODUCTION

This manual details the instructions on how to install and operate hardware of the High Performance Laser Scanning Module (**HPM10G4**). Included is information on setting up the hardware in preparation for your software commands, at which point you can refer to the proper software manual.

Be careful to observe the information in the Environmental Requirements section that alert you to the hazards and the laser beam path you can expect while running the **HPM10G4**.

Many of the details in this manual refer to the **XY10G4** Scan Head used within the **HPM10G4** module. This is because the **XY10G4** head is **extremely intricate**, and since it consists of the galvanometers that reflect the laser beam, it can be hazardous if certain precautions are not taken. Please be alert to the safety considerations and specific procedures regarding the **XY10G4** head and the laser you are using.

Conventions

Throughout the manual you will see graphic icons representing pertinent information in the text. The purpose of these icons is to provide a visual convention to alert you of a stop in the flow of the manual, where an important note or safety hazard alert is posted.





NOTE is an important procedure you should be aware of before proceeding.

CAUTION alerts you of a potential danger to equipment or the user.

WARNING indicates an imminent danger to the user.

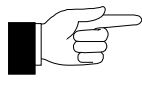
TIP and **REMINDER** are helpful hints to procedures listed in the text.

The conventions are listed as follows, showing both the text and the picture you will see.

NOTE	CAUTION	TIP	WARNING	REMINDER
				

1.1 Warranty

GSI LUMONICS (GSIL) warrants this product to be free from defects in materials and workmanship for 12 months from the date of shipment. GSIL will, at its option, repair or replace the product if it is defective within the warranty period and returned, freight pre-paid, to a service center designated by GSIL.

GSI LUMONICS requests that customers obtain a Return Authorization Number prior to returning units, and that they carefully pack units in their original packing or equivalent.

Under warranty, GSIL is not obligated to repair damage to any units resulting from the following conditions (customers are responsible for defining which conditions are applicable to their product):

- a) Personnel other than GSIL representatives attempting to repair or service the product.
- b) Improper use of the equipment.
- c) Connecting the product to incompatible equipment.
- d) Personnel other than GSIL representatives modifying the product.
- e) Scratches and chips on any optical surface after three weeks from the date of receipt.
- f) Damage to any optical surface from improper handling or cleaning procedures. This applies specifically to those items subjected to excess laser radiation, contaminated environments, extreme temperature or abrasive cleaning.

Customers assume all responsibility for maintaining a laser-safe working environment. OEM customers must assume all responsibility for **CDRH** (Center for Devices and Radiological Health) certification.

There is no implied warranty of fitness for a particular purpose, and GSIL is not responsible for consequential damages. Individual components manufactured by GSIL or others may be covered by their own warranties. Refer to the appropriate manuals for this information.



NOTE

1.2 Customer Support

GSI LUMONICS has support services available to you concerning problems with either the product or manual you are using.

Before calling for assistance, please make sure you refer to any appropriate sections in the manual that may answer your questions. The “Technical Outline Drawings” in APPENDIX B may be particularly helpful. If you need further assistance:

The customer service personnel will be able to give you direct assistance and answers to your questions.



U.S. (Massachusetts):	978-661-4300 (in the U. S.) +01 978-661-4300 (outside the U. S)
Germany (Munich):	+49 89 8991340
Italy (Monza):	+39 39 2025387
UK (Banbury):	+44 132 787 2424
Japan (Tokyo):	+81-33-406-7990

... ask for the GMAX Customer Service Department

1.3 Unpacking

A packing list is included in the shipment that details the exact items shipped.

- a) CAREFULLY unpack the contents from the box.
- b) Save shipping container and packaging material in case you need to return unit for service.
- c) Check contents of the box against the packing list to assure all parts have been received.
- d) Inspect each item to assure it is not damaged.

2. HPM10G4 OVERVIEW

2.1 Theory of Operation

The High Performance Laser Scanning Module (**HPM10G4**) is a multi-purpose-designed module. The module consists of 2 galvanometer scanners (X and Y), optics (flat field lens) and integrated driver electronics all enclosed in a black anodized aluminum case.

*X and Y Galvanometric
Scanners with a Flat
Field Lens*

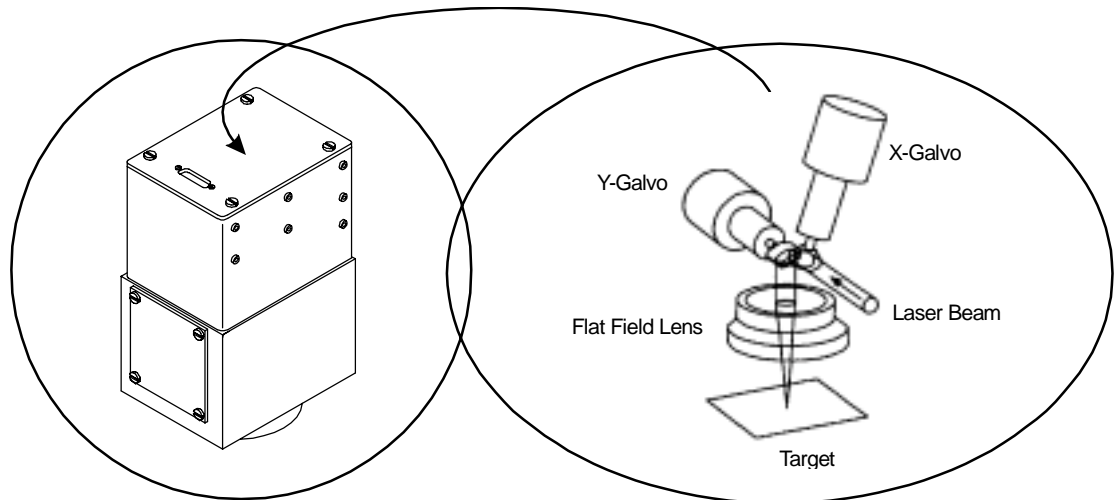

GSI LUMONICS'S 2-mirror, 2-axis galvanometer Scan Heads provide the capability of deflecting optical beams in an XY manner for all possible laser applications. The synchronized actions of two galvanometer servo-controlled turning mirrors direct the laser beam to specific locations on a target material surface in both the X and Y directions.

PC-MARK MT™ (or **PC-MARK**) and **JOB EDITOR™** (optional), sophisticated laser control software, controls the motion of the galvanometer according to the design selected by the user. The two circuit boards (galvanometer drivers) located in the Scan Head are connected to the computer controller through the **HelperCard** or **HC/2™**. A 25-pin interconnecting cable links the drivers to the **HelperCard** or **HC/2**.

2.2 General Description

The **HPM10G4** is a basic building block for the construction of a laser beam positioning system. It is intended for use by OEM customers, integrators, and sophisticated end-users. It consists of a purposely designed integrated deflection head with a PC based hardware and software package. The following block diagram shows the typical **HPM10G4** system components provided by GSI LUMONICS.

Block Diagram of a Typical HPM10G4 System

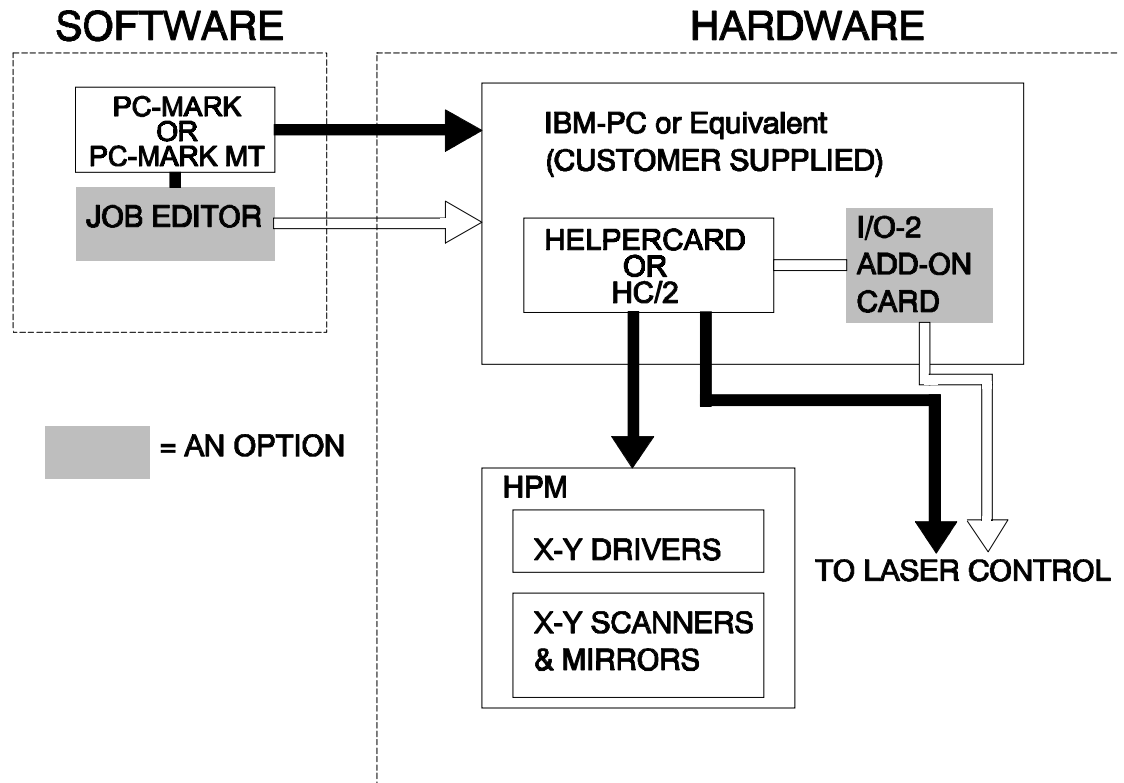

GSI LUMONICS provides the following items that make up the full HPM10G4 package:

- **XY10G4** Scan Head with 2 galvanometer scanners, optics and integrated driver electronics.
- PC-installed **HelperCard** or **HC/2** (I/O-2 add-on control card optional).
- 10 ft. digital interface cable.
- Software package **PC-MARK MT** (multitasking) or **PC-MARK**, (**JOB EDITOR** optional).
- Documentation.

The Customer must provide:

- A laser.
- A computer (IBM PC compatible).
- A method of mounting the **HPM10G4**.
- Power Supply with the following specifications:

Power Supply Specifications

Voltage	±15 V +5%-0%
Current	2A
Ripple	≤ 0.2%
Noise	≤ 0.5% DC to 30MHz

Minimal Computer Requirements

The minimal configuration for the computer depends on your **HC/2** or **HelperCard**. For more information see the appropriate manuals.

2.3 Specifications

Environmental Requirements

Storage Temperature:	-10°C to +60°C
Minimum Operation Temperature:	+15°C
Maximum Operating Temperature:	+34°C
Humidity:	Non-condensing

XY10G4 Scan Head

Specifications and Pin Configurations are located in “APPENDIX A: Specifications”.

Mirrors

Specifications are located in “APPENDIX A: Specifications”.

3. SAFETY AND WARNINGS

The United States Food and Drug Administration, through the Center for Devices and Radiological Health (CDRH), has promulgated regulations (21 CFR parts 1000 and 1040) controlling the safety of lasers and laser products for sale or manufacture in the United States. GSI LUMONICS **XY Scan Heads** are regulated by the CDRH.

This section is a guide to the specific areas of this product and to the manual(s). Pay particular attention to CDRH compliance information.

*User
Responsibilities*

GSI LUMONICS **XY Scan Head** are designed to provide maximum flexibility and ease of use. Such a design inherently requires the user to assure the overall safety of the configuration in use.

It is the user's responsibility to insure that:

- 1) Only lasers certified to comply to CDRH regulations are used with GSI LUMONICS **XY Scan Heads**.
- 2) Certified lasers contain features to assist in their safe usage. These protective features and the protective features within the GSI LUMONICS **XY Scan Heads** should not be defeated.



CAUTION

Prior to operating any configuration of the GSI LUMONICS XY Scan Heads, you must make a through analysis of system safety. Key information for this purpose is contained in this manual. You would thoroughly familiarize yourself with all this information before proceeding.

Laser Hazard Analysis

A full description of laser hazard analysis is beyond the scope of this manual. A good technical survey of laser safety requirements can be found in **ANSI Z136.1, "American National Standard For the Safe Use of Lasers"**. This is available from:

*American National Standards Institute, Inc.
1430 Broadway
New York, New York 10018*

Among the many other sources of laser safety information, the following institution offers several excellent publications.:

*The Laser Institute of America
5151 Monroe Street, Suite 118W
Toledo, Ohio 43623*

Final analysis of all safety features should be made by your Laser Safety Officer or a competent specialist in this field.

The first consideration in a safety analysis is the laser mated to the GSI LUMONICS **XY Scan Head**. The hazard level of the laser is roughly indicated by the Laser Class label that is on the device. A brief description of the radiation classes are shown in the following table.

Note that, besides radiation, lasers may present other hazards, e.g.; electric shock or creation of poisonous fumes.

Classes and Characteristics of Lasers

LASER CLASS	DESCRIPTION
Class I	Lasers are not considered to be hazardous.
Class IIa	Lasers are hazardous if viewed for periods greater than one thousand seconds.
Class II	Lasers are chronic viewing hazards.
Class IIIa	Lasers may represent acute, intrabeam viewing or chronic or acute viewing hazards when viewed with optical instruments.
Class IIIb	Lasers are an acute hazard to skin and eyes from direct radiation.
Class IV	Lasers are an acute hazard to skin and eyes from direct or scattered radiation.



CAUTION

Do not use equipment outside of these ranges, as additional hazards may result.

Because we do not determine the laser used with our product, all General Scanning end-user **XY Scan Heads** are labeled at the highest hazard level (Class IV). You should obtain information on output power or energy, wavelength(s) of output, duration of pulse, beam size and beam divergence from the manufacturer of the laser you are using.

The wavelength and power of the laser actually used should be written on the warning logo type label, Position 2. (See Section page 33699 and 33700 of the Federal Register, Appendix B). Be sure to use a permanent, indelible ink.

Class IV Warning Label

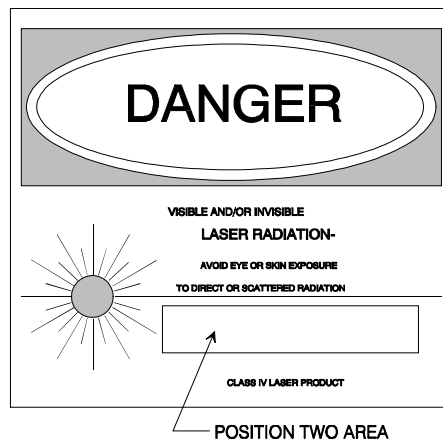

The Federal Register Rules and Regulations, Vol. 50, No. 161, dated Tuesday, August 20, 1985, contains the performance standards adopted by the Food and Drug Administration (FDA) which gives detailed information regarding the determination of laser classification and labeling. The ANSI and the FDA classifications are not the same. For purposes of labeling, use only the FDA classifications. If your laser falls in a classification below Class 4, replace the warning label type with the correct label and appropriate classification. The factory provides alternate labels upon request.



REMEMBER

The General Scanning **XY Scan Heads** provide you with the ability to aim the laser beam over a roughly pyramidal volume. The divergence of the focused beam beyond the focal point, which is a function of the lenses selected and their position, can cause radiation to exit the pyramid. When analyzing safety, you must consider all regions within this aiming pyramid, the divergent beam, and the effects of all focal possibilities in the zone of hazard. Reflections must also be considered.

3.1 Laser Shutter Installation



The laser attenuator (shutter) is not included with the **XY Scan Head**. Because each laser is unique, it is the user's responsibility to insure that such a device is incorporated in the installation in conformance with CFR regulations (1040.10[f][6]), which reads as follows:

A beam attenuator is required on Class II, IIIa, IIIb and IV laser systems. The beam attenuator is a mechanical or electrical device such as a shutter or attenuator that blocks emission. The beam attenuator blocks bodily access to laser radiation above Class I limits without the need to turn off the laser. The beam attenuator must be available for use at all times during operation. Power switches and key controls do not satisfy the attenuator requirement.



The beam shutter should be installed between the laser head and the Scan Head. The following figure shows the recommended location of the shutter.

We strongly recommend that you specify a laser with a vendor-supplied shutter mechanism. If this is not possible, consult the laser vendor to design a proper safety shutter.

Laser Scanner Hazard Zones of an HPM Scan Head

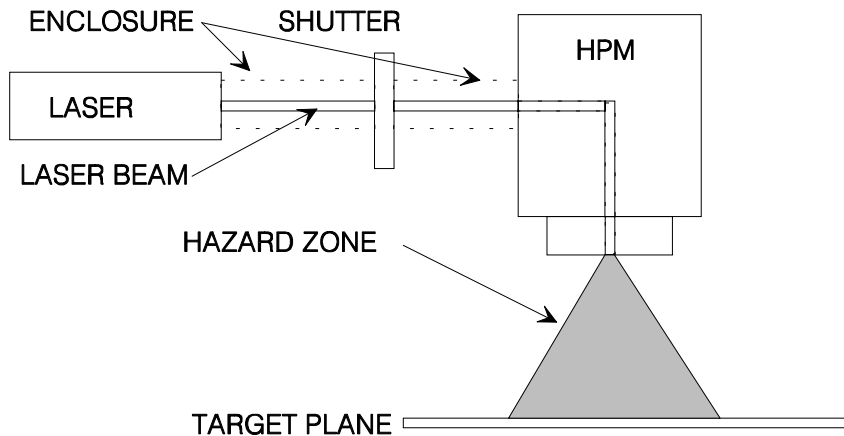

The figure shows the laser's internal and external optical path towards the target plane, specifically where the hazard zones are located as the optical beam passes through as **HPM Scan Head**.

3.2 Installation Safety Requirements

Because of the possible hazard increase of scanning stopping or slowing to an unsafe velocity, it is required that the controller software shuts down the laser power (a scanning safeguard).

In all cases, we recommend that you fully enclose and interlock the zone of hazard for your application to prevent possible opening while the laser is energized. When laser radiation exceeding Class 1 levels may exit the enclosure, you must have suitable protection for eyes available.



NOTE

At no time should you stare into the beam, place any parts of your body in the beam path, or expose yourself to reflections of powerful beams. You should use only a Class 1 HeNe Laser for alignment. If this is not possible, you should use the available laser's lowest power setting and remote beam sensing technique.



CAUTION

Using optical instruments with this product increases eye hazard.

Additional Safety requirements may be applicable during initial alignment of the optical system. Refer to Section, “Safety and Warnings”, Section 3.

General Scanning XY Scan Heads are labeled in conformance to the requirements of 21 CFR parts 1000 and 1040.

4. INSTALLATION

Installation Safety Requirements



WARNING

We recommend that you fully enclose and interlock the zone of hazard for your application to prevent possible opening while the laser is energized. If laser radiation exceeding Class 1 levels may exit the enclosure, you must have available suitable protection for your eyes.

At no time should you stare into the beam, place any parts of your body in the beam path, or expose yourself to reflections of powerful beams. You should use only a class I HeNe laser for alignment. If this is not possible, you should use the available laser's lowest power setting and remote beam sensing technique. Using optical instruments with this product increases eye hazard.

Additional Safety requirements may be applicable during initial alignment of the optical system. See the next section for specific safety information. General Scanning **XY10A/R** Scan Heads are labeled in conformance to the requirements of 21 CFR parts 1000 and 1040.

4.1 Handling the XY10G4 Scan Head Lens

If you have not purchased a lens with your **HPM10G4**, and you are installing your own lens, or you are removing a lens, follow the steps outlined below for handling and installing a lens.

Lens Mounting

YAG Lens Example

(Complete Assembly)

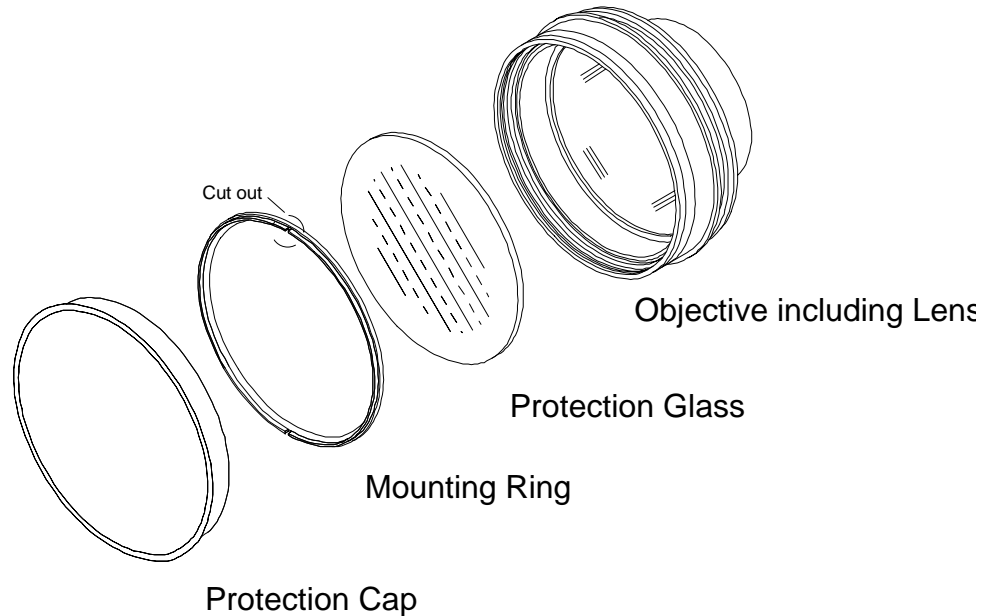

CAUTION

Make sure that the laser is off before performing any inspections! Wear finger cots or cotton gloves when handling optics for inspection.

To Install a Lens:

- 1) Before installing a lens onto the Scan Head, visually inspect the lens surface for any evidence of damage, i.e.; cracked lens, cracks on the edges of the lens, scratches on the lens surface.
- 2) If the lens is dirty, clean the lens per the lens cleaning instructions in the **MAINTENANCE**. Do not rest any objects on top of the lens as this may result in damaging the lens.
- 3) If there is a protection glass, make sure it is clean, then place it over the front of the lens. Screw the Mounting Ring into the lens flange until it is tight over the Protection Glass. Hand-fit lens protection cap onto the lens assembly.
- 4) The lens assembly is screwed into the Scan Head. Carefully and securely mount the lens to the **XY10G4** Scan Head. (DON'T CROSS-THREAD THE LENS ASSEMBLY). The lens should be screwed on completely.

To Remove a Lens:

Reverse the above procedure.

4.2 Mounting the XY10G4 Scan Head

Scan Head Outline

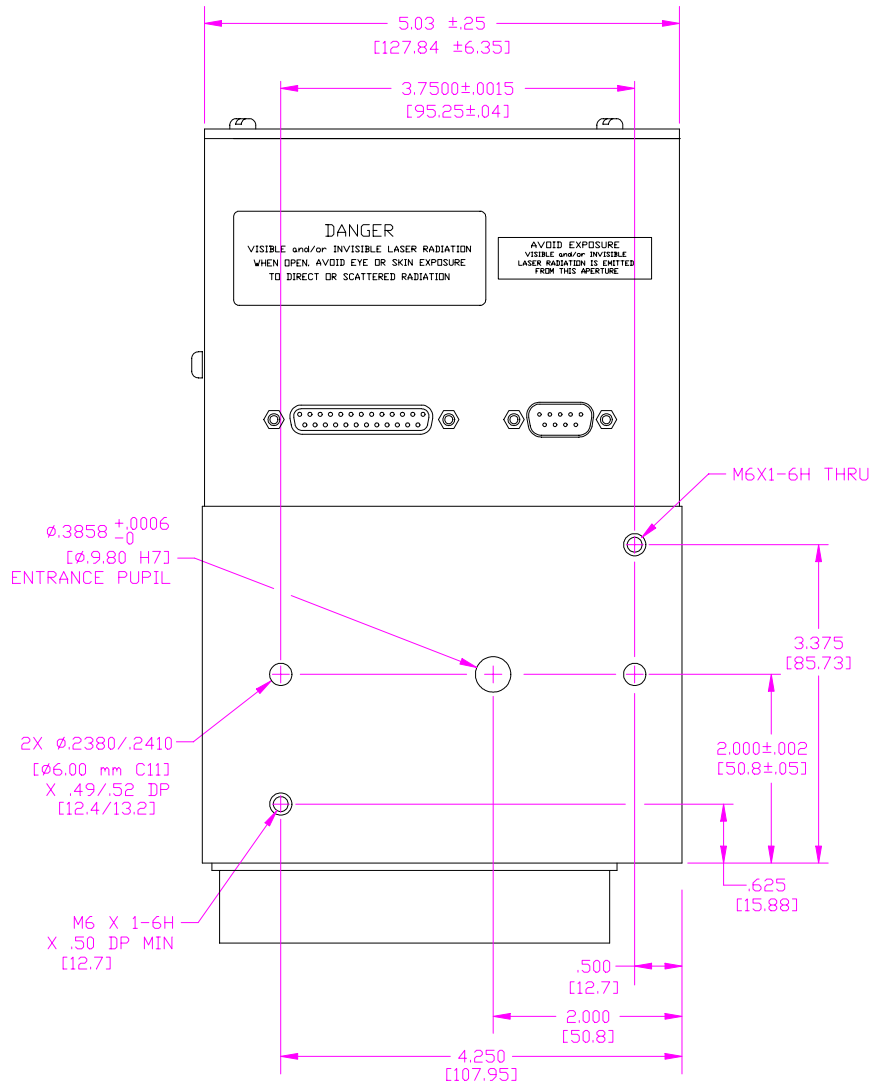

XY10G4 Mounting

- 1) The Scan Head requires a mounting flange that will match the mounting pins and holes on the **Beam Input** side of the assembly. The previous figure and the outline drawings, in Appendix C, can be used to determine the dimensions for manufacturing a mounting flange.
- 2) Line up the **XY10G4** Scan Head module dowel holes with the dowel pins which protrude from your mounting flange.
- 3) Install the **XY10G4** Scan Head module onto the pins.
- 4) Insert two M6 size buttonhead screws into the holes of the mounting flange. The screw length should be long enough to provide three or more full turns into the tapped holes.
- 5) Using an allen wrench, tighten the two screws. Alternate tightening the two screws so that the **XY10G4** Scan Head comes together evenly with the mounting flange.

4.3 HC/2 Card Installation

The purpose of the **HC/2 Card** is to provide a hardware link between the CPU and the **HPM10G4**. Card is designed to be installed into a PC type computer. For more information and installation procedure refer to the relevant manual.

4.4 Interconnections

The following figure depicts the connection of the **HPM10G4** Scan Head and the **HC/2** or **HelperCard** to the various other Customer-supplied parts of the system.

HPM10G4 Connected to a System

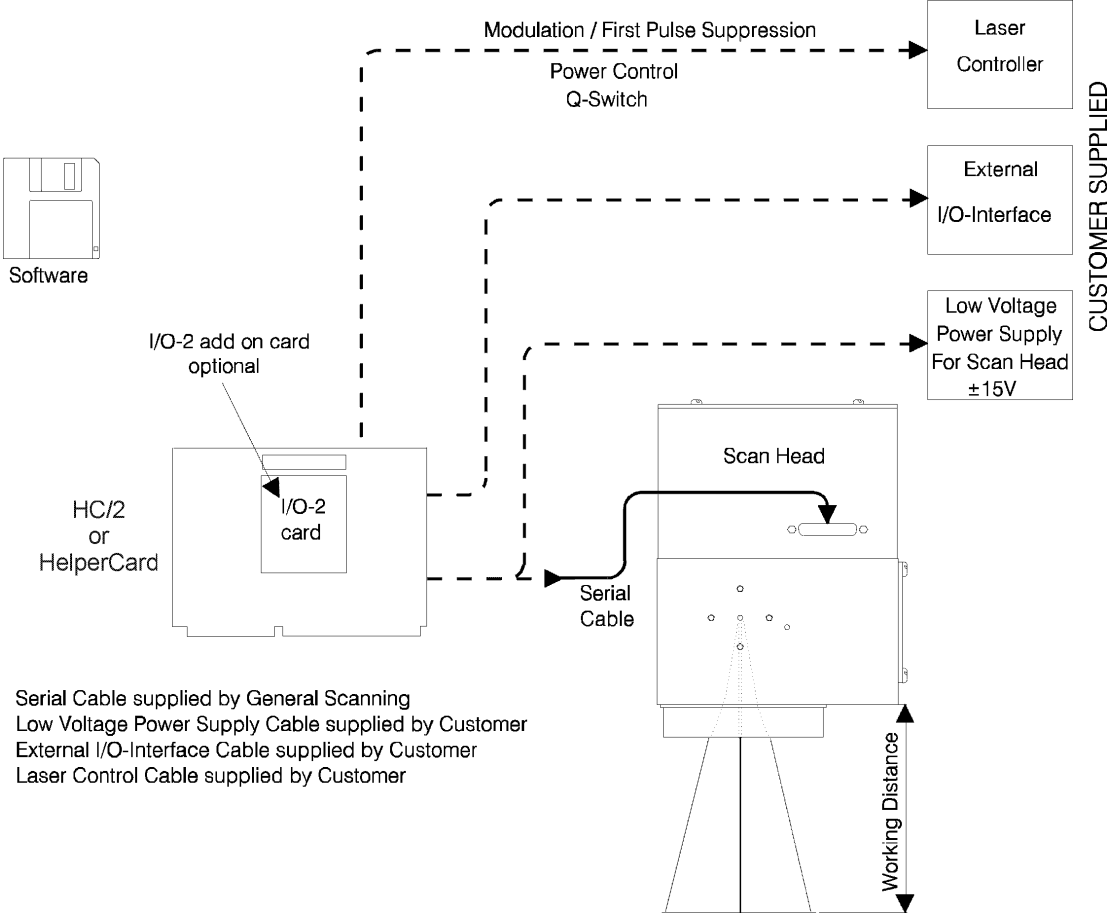

This completes the installation of the **HPM10G4** system. Install your software onto the computer. Refer to the software manuals for software installation.

5. MAINTENANCE

*Cleaning the
HPM10G4 Scan Head*

The HPM10G4 Scan Head assembly is sealed. The housing can be cleaned with a slightly dampened cloth. If a cleaning agent is necessary, use only a small quantity of non-aggressive cleanser (e.g. soap).

5.1 Lens / Protection Glass Cleaning

*Cleaning the Lens /
Protection Glass*

Special care should be exercised in cleaning a lens that does not have a protection window

5.1.1 Introduction

Optical materials and coatings are relatively soft materials and incorrect cleaning techniques can lead to surface damage and drastically reduced component lifetime.

Surface contamination can be of different kinds:

- Dust, grease and other air-borne particles.
- Products from the laser process - back spatter or burned-in particles.
- Organic contamination caused by talking, coughing or sneezing near the exposed optical surface.

The primary goal is to avoid any contamination by appropriate protection of the exposed optics!

The basic cleaning technique described here is intended to help prolong the component lifetime by minimizing surface damage during the cleaning process.



CAUTION

Not following this technique can cause severe damage to the optical components.

5.1.2 Basic Cleaning Procedure

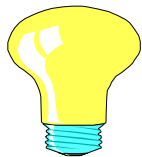

TIP

Optical components should always be handled using suitable gloves, or finger-cots, in order to avoid finger prints.

1. Surface dust and loose particles must be blown from the component using an air bulb, ideally one with a non-return valve.
2. Always use cloth or cotton buds which are moistened with **pure** acetone. Never use cleaning materials which are dry.
3. Use a soft, lint-free lens cloth. The cloth has to be moistened with pure acetone, laid gently on one edge of the component and drawn in a continuous movement to the opposite edge.

DO NOT APPLY PRESSURE. DO NOT RUB!



CAUTION

Rubbing may cause permanent surface marks.

4. Blow away residue liquid in one direction with an air bulb.
5. Make sure that no visual contaminants remain on the optical surface.
6. Stubborn stuck-on particles may require an attempt to dislodge them by the local application of a cotton bud moistened with pure acetone.
7. Finish off per (3) above.
8. Organic contamination cannot usually be removed using solvents such as acetone. The residue should be removed using distilled water and a lens cloth prior to finishing per (3) above.

5.1.2.1 Back-spatter / Burned-in Damage

Some forms of back-spatter can be reduced or removed using the basic cleaning process.

In general, however, metallic back-spatter or laser-burned-in damage cannot be removed by cleaning.

If the extent of the contamination is sufficient to cause process problems (e.g.: thermal lensing), then consideration should be given to replacement of the contaminated component.

5.2 Mirror



CAUTION

Never touch the coating of the mirror to avoid any damages on the surface.

There are times, however, when cleaning the mirror becomes a necessity. Follow exactly the next section "Cleaning Procedure".

5.2.1 Cleaning Procedure

Although the mirrors can be replaced by the user, we do **not recommend** you do so. Furthermore, **GSI LUMONICS does not recommend cleaning front surface mirrors.** Mirrors damaged by cleaning are not included under the warranty. The surface of these mirrors damages easily. It is difficult to prevent hard dust particles from being entrained in the process and causing scratches. In many cases, small defects in the mirror's surface may be less harmful than the surface damage resulting from continued cleaning. It requires special equipment typically not available to customers.

There are times, however, when cleaning the mirror becomes a necessity, e.g. stains such as fingerprints must be removed immediately to prevent permanent etching of the reflective surface. The information below includes general recommendations for those special occasions when mirrors must be cleaned.

Remove lint from mirrors with a jet of low pressure clean air. Blowing on front surface mirrors deposits moisture that may stain the finish.

Removing Dust

Removing Stains

A thin overcoating of silicon monoxide protects most mirrors from oxidation. Like many optical coatings, it is easily damaged when attempts are made to clean the mirror surface with a dry tissue.

The safest method of cleaning is to place a piece of lens tissue on the mirror surface and wet it with reagent grade (highly pure) alcohol or acetone (If you use acetone, take precautions regarding possible health and fire hazards). Grasp an overhanging corner of the tissue and gently agitate it several times, then slide the tissue off. This should remove the problem blemishes.



CAUTION

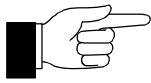

NOTE

Do not let solvent enter the bounding zone of the mirror.

Note that the mirror is not rubbed.

If the mirror surface is still contaminated, use a highly pure solvent such as alcohol or acetone and generously wet the mirror surface with a **sterile** cotton swab or lens tissue. Gently wipe the dirty areas. Turn your cotton swab or tissue with each stroke so that a clean area is exposed.



CAUTION

Do not let solvent enter the scanner bearings. When wetting the mirror's surface, hold the scanner at an angle so that the liquid does not wet the scanner. If any solvent is found in the bearings of the scanner, the warranty is voided.

6. TROUBLESHOOTING

If you encounter problems with your **HPM10G4**, you can check the following matrix. If you cannot solve the problem, contact **GSI LUMONICS** for further assistance.

PROBLEM	PROBABLE CAUSE	POSSIBLE SOLUTION
1. Decrease in marking quality.	1. Dirty protection glass.	1. Clean glass per instructions in Maintenance Section.
	2. Marking parameters changed.	1. Check PC-MARK MT and JOB EDITOR parameters.
	3. Drop in output power.	1. Check laser power.
2. Laser will not mark when ordered by computer.	1. Laser modulation malfunction.	1. Check connections between HC/2 and laser controller. 2. Check connections between laser controller and laser.
	2. No power to galvanometers.	1. Check power connections to scanning head.
	3. HC/2 malfunction.	1. Verify that HC/2 connections and installation are correct.

7. GLOSSARY

- Field Flattening Lens:* A wavelength specific lens focuses the laser to a small spot and maintains this spot size over the entire target field.
- Galvanometer:* A scanner with limited rotation magnetic torque motor with position feedback. The galvanometer (galvo) rotates a mirror to direct the laser beam.
- HC/2:* A PC based board that provides the hardware link between your PC and the XY Industrial Scan Head. I/O for laser control and parts handling are additional features. The HC/2 is fully compatible with PC-MARM MT (multitasking) software.
- HPGL:* HP® Graphics Language, a graphics format which PC-MARK MT can translate into vector data for scanning.
- HPM:* (High Performance Modules) Complete beam position packages consisting of the XY Industrial Scan Head, PC resident HC/2 card, PC-MARK MT software and interconnects.
- I/O-2:* An add-on board available as an option to the HC/2 card. Features include opto-isolated programmable I/O ports, analog laser power control and first pulse suppression.
- PC-MARK MT:* (multitasking) A powerful front-end macro command language. PC-MARK MT accepts application commands to place text and graphics in the marking field and translates them into the appropriate lists of vectors. Users may also write their own PC-MARK MT programs in any one of many popular software languages. MMCL is utilized as the link to the HC/2 card.
- JOB EDITOR:* A menu-driven application program of PC-MARK MT that provides an extensive graphics user interface and file management. It allows the user to manipulate HPGL based graphics with an accurate real preview of one's job.

8. APPENDIX A: Specifications

8.1 XY10G4 Scan Head

Laser Type	YAG			CO ₂	
	1,064 nm	1,064 nm	1,064 nm	10,600 nm	10,600 nm
Wavelength	1,064 nm	1,064 nm	1,064 nm	10,600 nm	10,600 nm
Objective (f in mm)	f = 100	f = 163	f = 254	f = 100	f = 200
Standard Field Size (mm ²)	55x55	115x115	180x180	60x60	120x120
Maximum Practical Field Size (mm ²) ¹	70x70	115x115	180x180	60x60	120x120
Spot Size TEM ₀₀ (μm)	~23	~31	~41	~230	~380
Working Distance (mm) ²	108	207	338	76	190
Resolution (μm) ³	< 4	< 7	< 11	< 4	< 8
Writing Speed (m/s) ⁴	> 1.8	> 3	> 4.5	> 1.8	> 3.5
Uncalibrated Non-Linearity (maximum %) ⁵	±0.6	±0.6	±0.6	±1.0	±1.0
Temperature Drift (maximum μm/°C) ⁶	7.7	12.7	19.8	6.6	13.2
Aperture (mm)	9.5	9.5	9.5	9.5	9.5
Scan Angle (maximum)	±20°	±20°	±20°	±20°	±20°
Power Capability, cw (W/cm ²) ⁷	500	500	500	500	500
Power Capability, 100 ns pulsed (MW/cm ²)	100	100	100	400	400
Protection Glass	yes	yes	yes	none	none
Scan Head Size ⁸ (height x length x with in mm)	128x209x165	128x222x165	128x241x165	128x201x165	128x201x165
Weight (kg) ⁹	5.3	5.8	6.3	5.2	5.2
Surface Finish	black anodized	black anodized	black anodized	black anodized	black anodized
Protection	IP40+	IP40+	IP40+	IP40+	IP40+

¹ Some beam clipping can occur

² Distance between edge of head and working field

³ Better than 2 bit in a 16-bit system (±0.003 %)

⁴ Actual writing speed depends on accuracy and feature sizes (jump speeds can be much higher)

⁵ Includes lens distortion; non-linearity can be improved by an order of magnitude by using individual calibration methods in software

⁶ Temperature drift is maximum 0.011 %/°C and typ. 0.008 %/°C

⁷ Determined by the mirror specifications

⁸ Scan Head basic dimensions without the lenses: Height = 128 mm, Length = 201 mm, Width = 165 mm

⁹ Scan Head weight without lens: 5 kg

Non-lens mirror configuration options: Argon, Argon (HP), UV and Visible

8.2 XY10G4 Scan Head Mirror

	LASER TYPE					
	YAG	CO2	ARGON	ARGON (HP)	UV	VISIBLE
Wavelength	1,064 nm	10,600 nm	488-514 nm	488-514 nm	325-360 nm	450-700 nm
Coating	Dielectric	Dielectric on Metal	Dielectric	Dielectric	Dielectric	Durable Ag
Reflection (min.) @ Wavelength (nm)	99.5% @ 1,064 80.0% @ 450-650	99.5%	98.0% @ 480-514 50.0% @ 633	99.5%	98.0% @ 325-350 95.0% @ 350-360 45.0% @ 633	96.0%
Flatness @ 633 nm	$\lambda/4$	$\lambda/4$	$\lambda/4$	$\lambda/4$	$\lambda/4$	$\lambda/4$
Power Capability, cw (W/cm²)	500	500	100	5 MW/cm ²		10
Power Capability, 100 ns pulsed (MW/cm²)	100	400	80	2 GW/cm ² (10 ns pulsed)		N/A
Surface Quality (Scratch/Dig)	40/20	40/20	40/20	40/20	40/20	40/20

See your GSI LUMONICS sales representative for more details.

8.3 XY10A/R Scan Head Pin Configurations

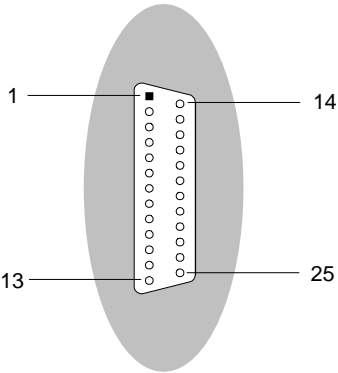
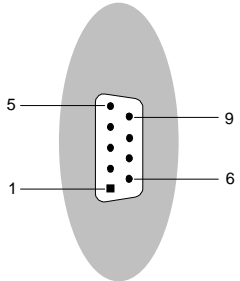
INTERFACE	PIN	ASSIGNMENT
 <p>25 Pin D-Sub female connector for HC/2 or HelperCard</p>	1	SENDCK -
	14	SENDCK +
	2	SYNC -
	15	SYNC +
	3	CHANNEL X -
	16	CHANNEL X +
	4	CHANNEL Y -
	17	CHANNEL Y +
	5	RESERVED FOR Z AXIS
	18	RESERVED FOR Z AXIS
	6	STATUS -
	19	STATUS +
	7	NC
	20	NC
	8	POSACK -
	21	POSACK +
	9	NC
	22	NC
	10	NC
	23	NC
	11	NC
	24	NC
	12	NC
	25	NC
	13	NC
INTERFACE	PIN	ASSIGNMENT
 <p>9 Pin D-Sub male connector for power supply</p>	5	+VSS1
	9	+VSS1
	4	+VSS2
	8	GND
	3	GND
	7	GND
	2	-VSS2
	6	-VSS1
	1	-VSS1

9. APPENDIX B: Technical Outline Drawings

This Appendix includes the following outline drawings:

OUTLINE DRAWINGS

3CD-17861

3CD-17863

ECD-20153

INDEX

—C—

Computer Requirements, 7
Customer Support, 3

—F—

Federal Register, 10

—G—

Glossary, 23

—H—

HPM10G4
Definition, 5
Interconnections, 16
Troubleshooting, 21

—I—

Installation
HC/2, 15
HelperCard, 15

—L—

Laser
Classes, 10
Hazard Zones, 11
Shutter Installation, 11
Shutter Location, 11
Warning Label, 10

Lens
Cleaning, 17
Mounting, 13

—M—

Maintenance
HPM10G4 Cleaning, 17
Lens Cleaning, 17
Mirror Cleaning, 18
Protection Glass Cleaning, 17

Mirror
Cleaning, 18

—P—

Power Supply
Specifications, 7

Protection Glass
Cleaning, 17

—S—

Specifications
Environmental, 7
Mirrors, 7, 26
Power Supply, 7
Scan Head, 7, 25

—W—

Warranty, 2

—X—

XY10G4
Lens Mounting, 13
Mirror Specifications, 26
Mounting, 14
Pin Configurations, 27
Specifications, 25